

### Introduction to the Lawnmower Powered Wooden Go-Kart

This set of plans will show you how to make a wooden go-kart, and to power it with a small lawnmower engine. The build of this kart will be very straight forward using commonly available DIY tools. This go-kart uses the same construction as the Basic Wooden Go-Kart at "[www.kartbuilding.net/Wooden\\_Go-Kart\\_Plans](http://www.kartbuilding.net/Wooden_Go-Kart_Plans)" with some changes to the rear axle, and the addition of a lawnmower engine at the rear. If this is your first time building a go-kart, try making that kart first, and then afterwards, adapt it to suit these plans.

While it is possible to make this go-kart without the use of a Welder (Arc Welder, TIG Welder, MIG), 3 components in this design are Welded. There will be alternative procedures listed, however they will require considerable more work. It would be possible to take these 3 components to an Engineering Works (Foundry / Metalwork Company) and get them to weld these parts for €10.

These kart plans are not for building the ultimate or best go-kart. These plans use a very simple and crude design to allow someone build a kart and to drive it with an engine. The plans focus more on engineering specifics and how to build various parts of the kart.

Safety is a very important issue. The author recommends that adult supervision is present at all times when testing and driving the kart. While there are details for adding brakes, the design of this kart is very crude and dangerous, and could cause serious harm to a person. The author of these plans is not responsible for anything that may happen to a person building or driving this kart.

If you have any specific question, feel free to email [kartbuilding@gmail.com](mailto:kartbuilding@gmail.com)

<p><b>PROPRIETARY AND CONFIDENTIAL</b> THE INFORMATION CONTAINED IN THIS DRAWING IS THE SOLE PROPERTY OF THE DESIGNER. ANY REPRODUCTION IN PART OR AS A WHOLE WITHOUT THE WRITTEN PERMISSION OF THE DESIGNER IS PROHIBITED.</p>	<p><b>kartbuilding.net</b> </p>	
	<p>TITLE: INTRODUCTION</p>	
<p>MATERIAL AS SPECIFIED</p>	<p>DATE: 26/02/2011</p>	
<p>FILE NAME: Main-Wooden-Kart-Inches-</p>	<p>SIZE: A4</p>	<p>REV. 1</p>
<p>SCALE: 1:20</p>	<p>DESIGNER: STEPHEN BURKE</p>	<p>SHEET 1 OF 21</p>

STANDARD LAWNMOWER ENGINE WITH A VERTICAL OUTPUT SHAFT

HAND LEVER FOR REAR BRAKES

CLUTCH LEVER ALLOWING THE KART TO START / STOP WITHOUT STOPPING THE ENGINE

THROTTLE (GAS) LEVER

FRONT AXLE (PIVOTS AND ROTATES) THE DRIVER MUST USE THEIR FEET TO PIVOT AND STEER THE GO-KART

### Controls of the Wooden Go-Kart

The controls for this kart are very basic. There is a brake lever (from a bicycle), a throttle/gas lever (off a lawnmower), and a standard lawnmower engine.

Steering is done with the drivers feet. The driver uses their feet and legs to pivot and rotate the front axle. There is also a "Clutch" lever on this kart. This will allow the engine to be started, without the go-kart moving off. When disengaged, it will also allow the kart to be stopped, and driven off again without having to stall / restart the engine.

The controls of this kart is very different from a normal go-kart, and quite the opposite in fact! Steering is done with your feet, and brakes / accelerator done with your hands. Again, the motivation behind this kart is to allow anyone with some DIY tools to make a go-kart and to drive it with an engine. Once you have mastered this kart, you can move on, and build a metal go-kart with full steering, a bigger engine and transmission.

PROPRIETARY AND CONFIDENTIAL  
THE INFORMATION CONTAINED IN THIS  
DRAWING IS THE SOLE PROPERTY OF THE  
DESIGNER. ANY REPRODUCTION IN PART OR  
AS A WHOLE WITHOUT THE WRITTEN  
PERMISSION OF THE DESIGNER IS PROHIBITED.

kartbuilding.net



TITLE: CONTROLS

MATERIAL AS SPECIFIED DATE: 26/02/2011

FILE NAME: Main-Wooden-Kart-Inches- SIZE: A4 REV. 1

SCALE: 1:20 DESIGNER: STEPHEN BURKE SHEET 2 OF 21



### Parts List (Shopping List)

The numbers listed on this page match up with the complete Parts List table on the next page. All the nails used to join the wood together are not shown.

Each part has a specific number as shown on this page. These numbers will be used throughout these plans to refer to specific parts.

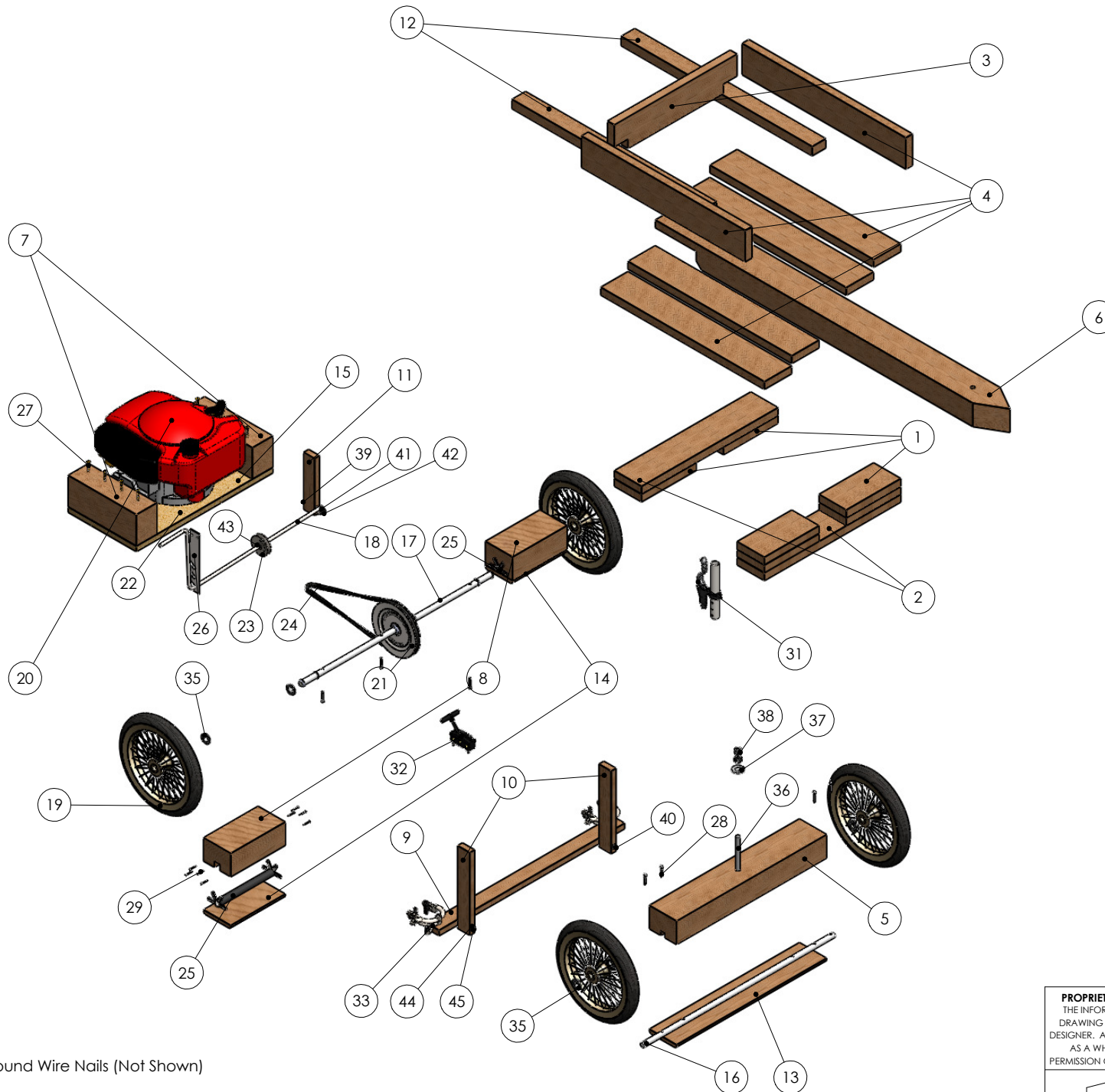

① Round Wire Nails (Not Shown)

③ Brake & Throttle Cable (Not Shown)

PROPRIETARY AND CONFIDENTIAL  
THE INFORMATION CONTAINED IN THIS  
DRAWING IS THE SOLE PROPERTY OF THE  
DESIGNER. ANY REPRODUCTION IN PART OR  
AS A WHOLE WITHOUT THE WRITTEN  
PERMISSION OF THE DESIGNER IS PROHIBITED.

kartbuilding.net



TITLE: PARTS LIST

MATERIAL AS SPECIFIED

DATE: 26/02/2011

FILE NAME: Main-Wooden-Kart-Inches-

SIZE: A4

REV. 1

SCALE: 1:20

DESIGNER: STEPHEN BURKE

SHEET 3 OF 21

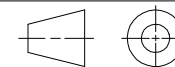



ITEM	QUANTITY	NAME	DESCRIPTION / SIZE	TOTAL LENGTH
1	6	Rear_Axle_Padding	4" Wide x 1" Thick x 8" Long	21.3 Feet
2	2	Cross_Chassis_Support_Member	4" Wide x 1" Thick x 20" Long	
3	1	Back_Chassis_Member	4" Wide x 1" Thick x 18" Long	
4	6	Common Chassis Member	4" Wide x 1" Thick x 24" Long	
5	1	Front_Axle_Support	4" Wide x 3" Thick x 22" Long	9.2 Feet
6	1	Main Chassis Member	4" Wide x 3" Thick x 50" Long	
7	2	Engine-Mount-Spacer	4" Wide x 3" Thick x 10" Long	
8	2	Rear_Axle_Support	4" Wide x 3" Thick x 8" Long	
9	1	Brake-Mount-Member	2" Wide x 1" Thick x 27.2" Long	5 Feet
10	2	Brake-Side-Mount	2" Wide x 1" Thick x 10.4" Long	
11	1	Belt-Tensioner-Hinge	1.6" Wide x 1" Thick x 8" Long	*
12	2	Rear-Engine-Support-Arms	2" Wide x 1.2" Thick x 28" Long	* Wood (Pine)
13	1	Front_Axle_Support_Cover	4" Wide x 0.5" Thick x 22" Long	3.2 Feet
14	2	Axle_Support_Cover	4" Wide x 0.5" Thick x 8" Long	
15	1	Engine-Mount-Board	6" Wide x 1" Thick x 20" Long Plywood Board	*
16	1	Metal Axle (Front)	Diameter 0.6" x 28" Long Solid Steel Bar	5 Feet
17	1	Metal Axle (Rear)	Diameter 0.6" x 28" Long Solid Steel Bar	
18	1	Belt-Tensioner-Lever	Diameter 0.32" Solid Steel Bar 32" Long Bent to Shape	*
19	4	Spoked_Bike_Wheel	Diameter 12" Wheels with Steel Hub	**
20	1	Lawnmower-Engine	Standard Lawnmower Engine with Vertical Drive Shaft	***
21	1	Steel-V-Belt-Pulley-Wheel	Diameter 6.4" Pulley Wheel to suit 0.4" Wide Belt	****
22	1	Aluminium-V-Belt-Pulley-Wheel-Small	Diameter 1.4" Pulley Wheel to suit 0.4" Wide Belt	****
23	1	Aluminium-V-Belt-Pulley-Wheel-Tensioner	Idler Pulley Wheel. Diameter 2.4" to suit 0.4" Belt	****
24	1	V Belt	0.4" Wide V-Belt (38" LONG)	****
25	2	Rear_Axle_Bushing	Outside Diameter 0.8" Steel Pipe (0.1" Wall) x 10" Long	*
26	1	Belt-Tensioner-Keeper	1.4" Wide x 0.08" Thick x 8" Long Flat Steel	*
27	16	wood-screw	1.8" Long Wood Screws for Engine Mount Board	*
28	8	Split Pin 5mm	Split Pins to accompany Washers on Front & Rear Axles	*
29	16	1-Inch-Round-Wire-Nail	Nails to secure Rear Axle Bushing to Supports	*
31	300 Pieces	Round Wire or Oval Nails	Roughly 1 Box of 2" Nails & 1 Box of 4" Nails	*
31	1	Brake Lever	Brake Lever & Handle from a Bicycle	*
32	1	Throttle-Lever	Throttle / Accelerator Lever from a Lawnmower	**
33	2	Horse-shoe-brake	Calliper Brake from a Bicycle	***
35	2	Brake & Throttle Cable	Brake Cable & outer Sheath/Cover from a Bicycle	** 2 x 3.3FT. (40') Cable
35	8	M0.64" Plain Washer	Washers for Front Wheels & Rear Axle Supports	**
36	1	M0.5" Hex Bolt x 6" Long	6" Long M0.5" (Diameter) Steel Bolt for Front Axle Pivot	*
37	1	M0.5" Plain Washer	Washer to accompany Front Axle Pivot Bolt	*
38	2	M0.5" Hex Nut	2 Nuts to Accompany Front Axle Pivot (or 1 Lock Nut)	*
39	5	M0.32" Hex Bolt x 2.6" Long	4 Bolts to secure Engine & 1 Bolt for Belt Tensioner	*
40	2	M0.24 Hex Bolt x 4" Long	M0.4" Hex Bolt x 4" Long for Brake Mount Member	*
41	8	Bright washer BS 4320 - M0.32" (Form A)		*
42	6	Hexagon Nut ISO - 4032 - M0.32" - W - N		*
43	2	ISO 1234-2x10-C		*
44	2	Bright washer BS 4320 - M0.24" (Form A)		*
45	2	Hexagon Nut ISO - 4032 - M0.24" - W - N		*

### Parts List (Shopping List)

This page outlines all the parts and components needed to make this lawnmower powered wooden go-kart. Depending on how much is in your garage, you might not have to buy many parts. If you don't have any of these parts available, then you should be able to source these parts from a hardware / DIY store, a Bicycle Shop, and a Lawnmower Repair Shop. Below are some typical places you will be able to get or buy the required parts. Further information on sourcing parts and their costs will be outlined on the [www.kartbuilding.net](http://www.kartbuilding.net) website.

- \* = Hardware Store (e.g. B&Q / Homebase / Lowes)
- \*\* = From an old small children's bicycle
- \*\*\* = From an old petrol/gas Lawnmower
- \*\*\*\* = From a car garage (scrap car yard, old washing machine)



**PROPRIETARY AND CONFIDENTIAL**  
THE INFORMATION CONTAINED IN THIS DRAWING IS THE SOLE PROPERTY OF THE DESIGNER. ANY REPRODUCTION IN PART OR AS A WHOLE WITHOUT THE WRITTEN PERMISSION OF THE DESIGNER IS PROHIBITED.

<b>kartbuilding.net</b>			
TITLE: PARTS LIST TABLE			
MATERIAL AS SPECIFIED		DATE: 26/02/2011	
FILE NAME: Main-Wooden-Kart-Inches-	SIZE: A4	REV. 1	
SCALE: 1:20	DESIGNER: STEPHEN BURKE	SHEET 4 OF 21	

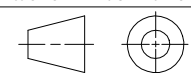

TOOL REQUIRED	DESCRIPTION / PURPOSE
Claw Hammer	Used to Hammer in Nails and remove nails.
Hand Saw	Used to Cut Wood to correct length.
Chisel	Used to cut grooves, slots and notches in Wood.
Hacksaw	Used to cut Metal (cut axles and steel pipe to length)
Electric Drill	Used to drill holes in Metal & Wood (drill holes in axles for split pins)
Various Drill Bits (HSS)	Drill Bits to drill holes in Metal (high speed steel)
Spanners / Adjustable Wrench	Used for tightening nuts and bolts.
Pliers / Vise-Grips	Used for Gripping and bending steel.
Screwdriver(s)	Used for screwing screws into wood.
Metal File	Used for Filing & Grinding Metal
Measuring Tape	To measure lengths of wood, metal etc.

TOOL OPTIONAL	DESCRIPTION / PURPOSE
Welder	Welder for joining Metal together.
Circular Saw (Skill Saw)	Cutting a Groove in the Front and Rear Axle Supports.



### Tools Required

The table above lists the tools required to make this go-kart. It lists the minimal amount tools required. Most of the tools listed should be in your garage. If not, you might be able to borrow them from a neighbour or purchase them in a Hardware store. Other tools can be used to make tasks easier. I.E. an electric angle-grinder can be used instead of a Hacksaw and File. An electric screwdriver can be used, and a Socket Wrench can be used instead of spanners.

### Tools Optional

#### A welder.

Although it is possible to make this kart without the use of a welder, it greatly reduces the time and effort required to make this kart. There are 3 parts of the rear axle which need to be joined together. Welding is the easiest option. If you don't have a welder or your neighbour doesn't have a welder, it would be possible for you to take the 3 parts to an Engineering / Metalwork company, or a High-school (which teaches metalwork) and get them welded. An alternative to welding these 3 parts will be outlined later in the plans.

#### A circular saw.

While it is most definitely possible to cut the groove / slot in the Front and Rear Axle supports using a Hand Saw and Chisel, having a circular saw, or getting someone to use it for you will save a few hours of work. Using a circular saw, making 4 saw cuts (with the depth of the saw blade set to 0.6") will remove the groove in minutes. This procedure will be outlined later in the plans.



<p><b>PROPRIETARY AND CONFIDENTIAL</b> THE INFORMATION CONTAINED IN THIS DRAWING IS THE SOLE PROPERTY OF THE DESIGNER. ANY REPRODUCTION IN PART OR AS A WHOLE WITHOUT THE WRITTEN PERMISSION OF THE DESIGNER IS PROHIBITED.</p>		
	<b>TITLE: TOOLS REQUIRED</b>	
	MATERIAL AS SPECIFIED	DATE: 26/02/2011
	FILE NAME: Main-Wooden-Kart-Inches-	SIZE: A4
SCALE: 1:20	DESIGNER: STEPHEN BURKE	SHEET 5 OF 21

## Breakdown of Main Areas of the Kart

Below is a list of how the main areas of the kart need to be broken down. The order of the breakdown shows how each of the areas should be tackled and constructed. The chassis is first to be built, followed by the front and rear axles. The last item in the breakdown is the final assembly, and fitting of the controls, such as brake & throttle / gas levers and the associated cables. The order of subsequent pages in these plans follows this breakdown.

1. Chassis
2. Front Axle Assembly
3. Rear Axle Assembly
4. Engine Assembly
5. Clutch / Belt Tensioner
6. Brakes
7. Final Assembly and Controls (omitted from diagram below)

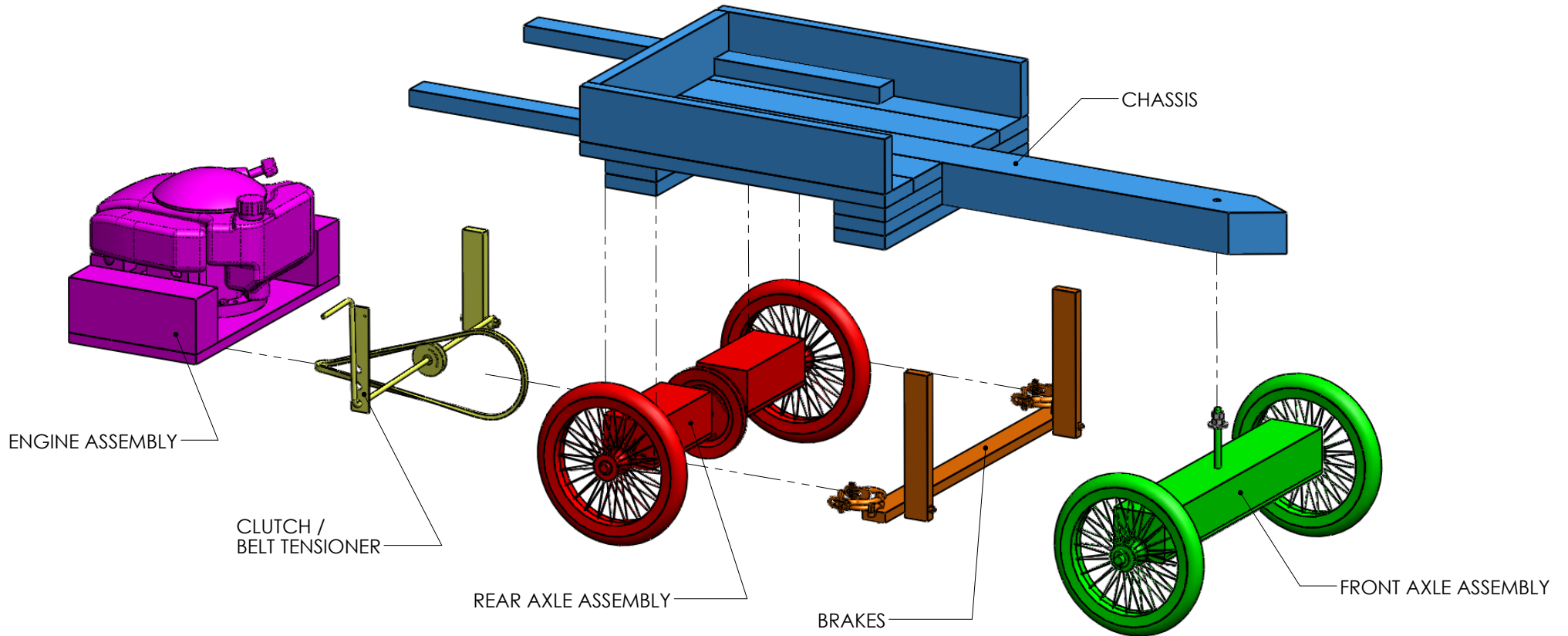

PROPRIETARY AND CONFIDENTIAL  
THE INFORMATION CONTAINED IN THIS  
DRAWING IS THE SOLE PROPERTY OF THE  
DESIGNER. ANY REPRODUCTION IN PART OR  
AS A WHOLE WITHOUT THE WRITTEN  
PERMISSION OF THE DESIGNER IS PROHIBITED.

kartbuilding.net



TITLE: BREAKDOWN OF KART

MATERIAL AS SPECIFIED

DATE: 26/02/2011

FILE NAME: Main-Wooden-Kart-Inches-

SIZE: A4

REV. 1

SCALE: 1:20

DESIGNER: STEPHEN BURKE

SHEET 6 OF 21

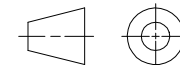

# MAIN CHASSIS #1

The main sizes of wood used in making the chassis are: 4" x 1", 4" x 3" and 2" x 1.2" (inches). Nails are used to fix the wood together. There is no need to use Glue. Make sure that the nails are long enough to break through the other side. Then the nails can be "clinched" or bent over on the other side. This makes for a very strong connection, whereby the two pieces of wood cannot be easily pulled apart. Try and avoid "splitting" the wood by not hammering in too many nails. It is also possible to flatten or dull the sharp tip of the nails (hammer the nail on its tip a few times), and this will reduce the chances of splitting wood. 2" Inch and 3" Inch Round Wire Nails are used throughout. Make sure not to use weak timber / wood which may be very light or contain lots of "knots" or splits. Notches / Pieces will have to be taken out of 2 pieces of wood. A 0.47" hole will have to be drilled in the Main Chassis member. These will be shown on the next page.

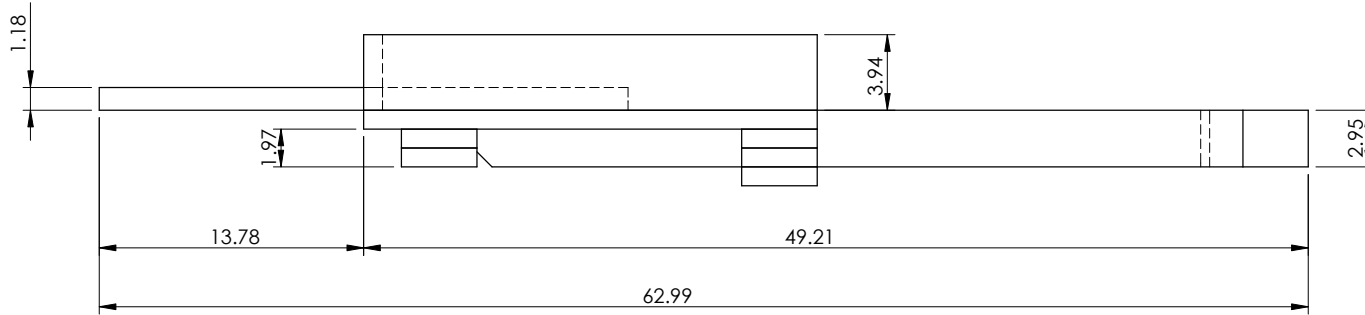
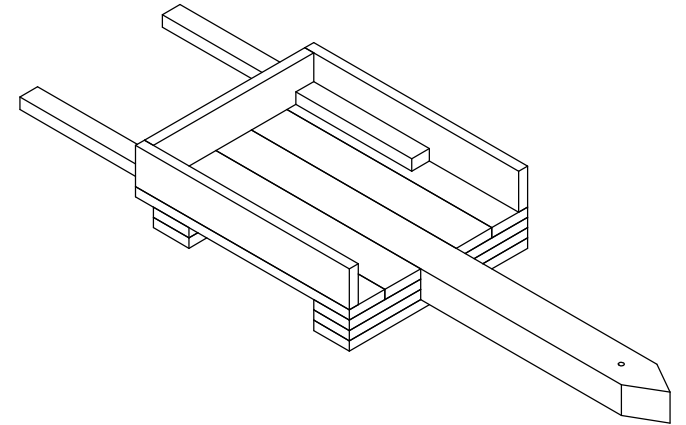

When nailing wood together, the nails should extend and protrude on the other side, where they can be "clinched" and bent over. This makes for a very strong connection.

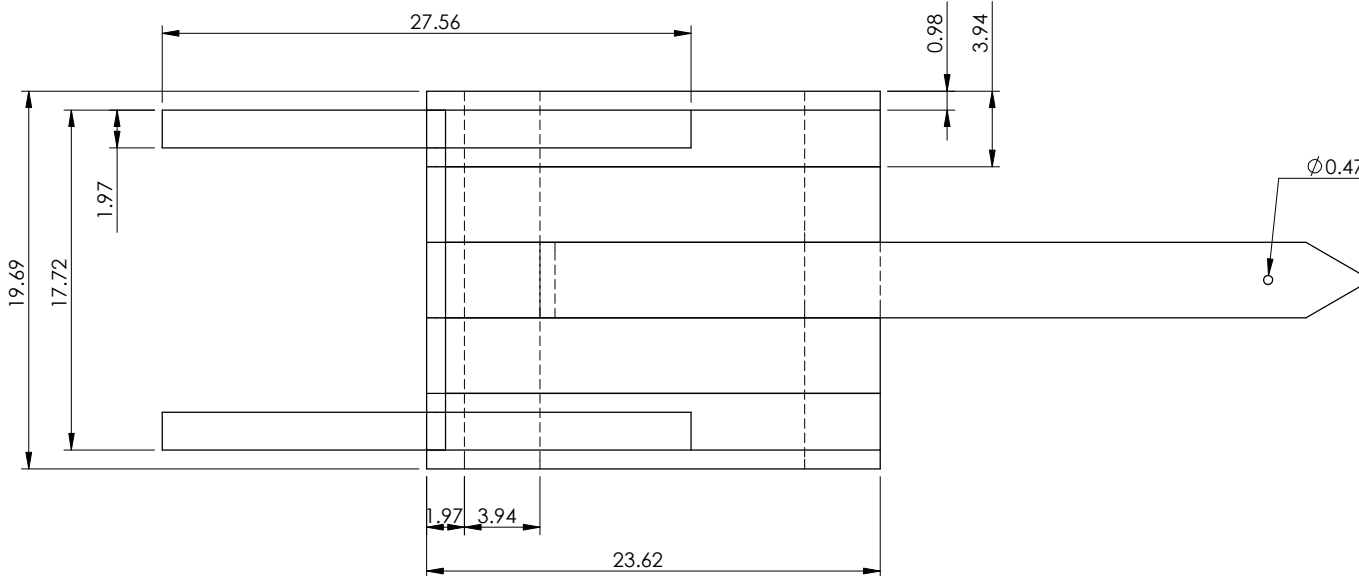

For the Rear Axle Padding pieces, nail 2 pieces together firstly, then secure this block to the chassis.

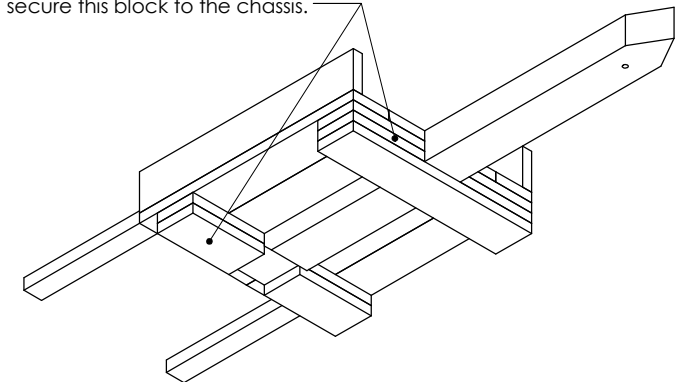

<b>PROPRIETARY AND CONFIDENTIAL</b> THE INFORMATION CONTAINED IN THIS DRAWING IS THE SOLE PROPERTY OF THE DESIGNER. ANY REPRODUCTION IN PART OR AS A WHOLE WITHOUT THE WRITTEN PERMISSION OF THE DESIGNER IS PROHIBITED.		<b>kartbuilding.net</b>	
TITLE: <b>CHASSIS #1</b>			
MATERIAL AS SPECIFIED		DATE: 26/02/2011	
FILE NAME: Main-Wooden-Kart-Inches-	SIZE: A4	REV. 1	
SCALE: 1:20	DESIGNER: STEPHEN BURKE		SHEET 7 OF 21

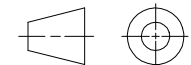

## MAIN CHASSIS #2

There are 6 different parts in the Chassis. Each of the 6 components can be seen below, and also labelled on the top right. For a quantity of each of the parts required see SHEET 4.

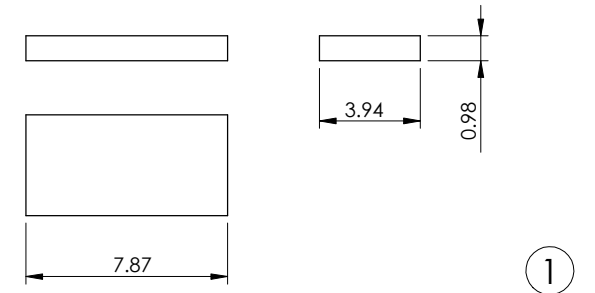
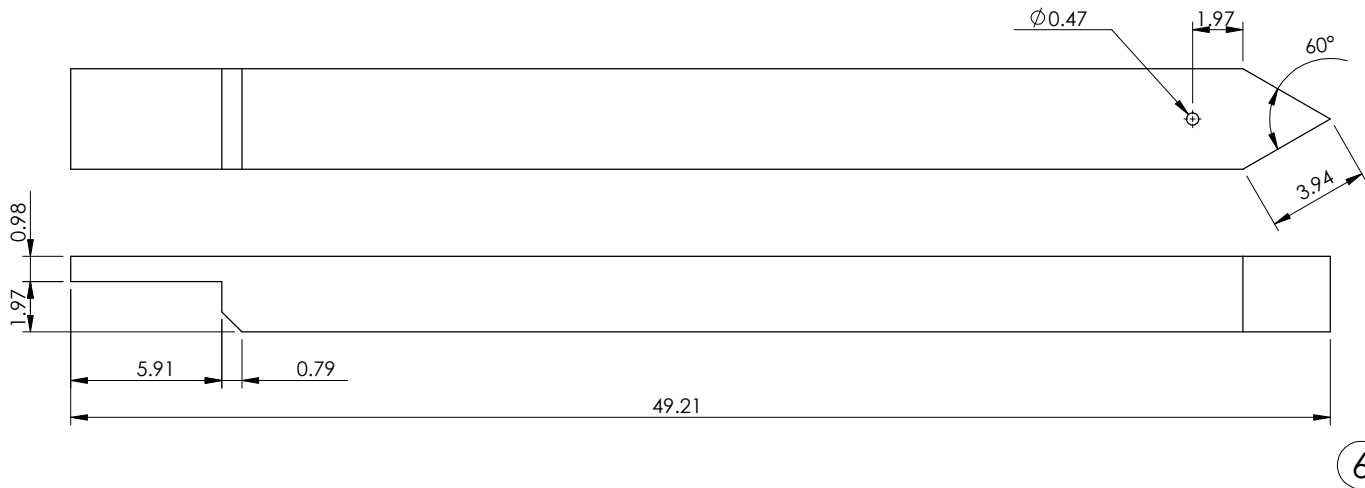
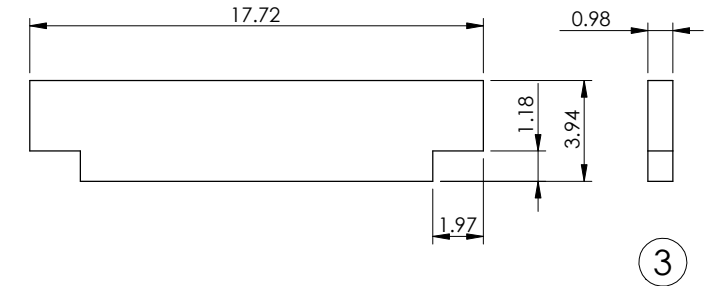
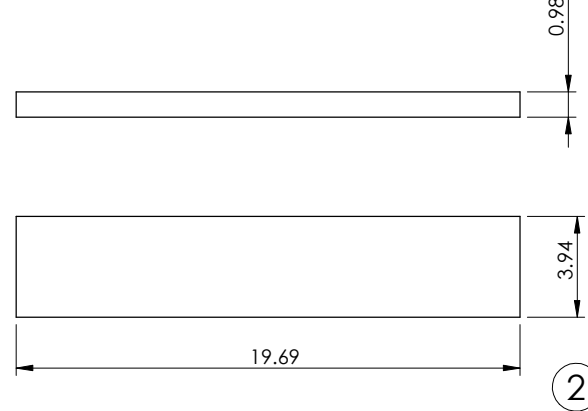
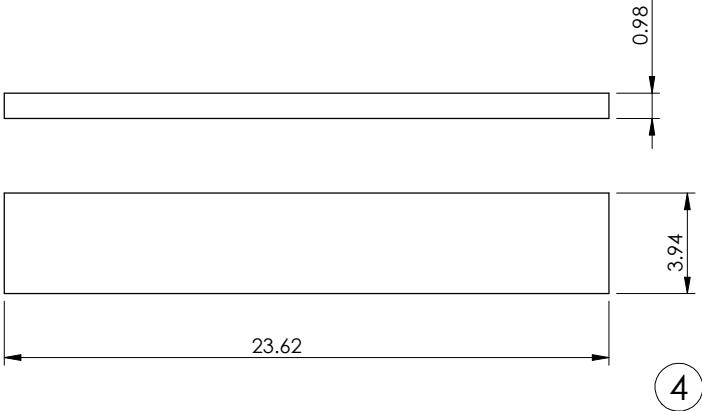
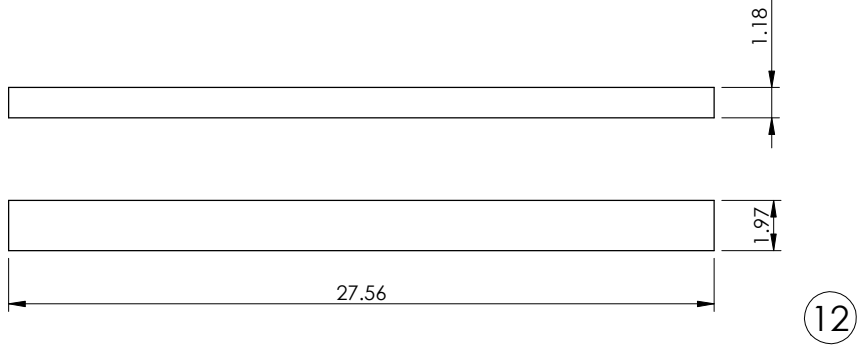
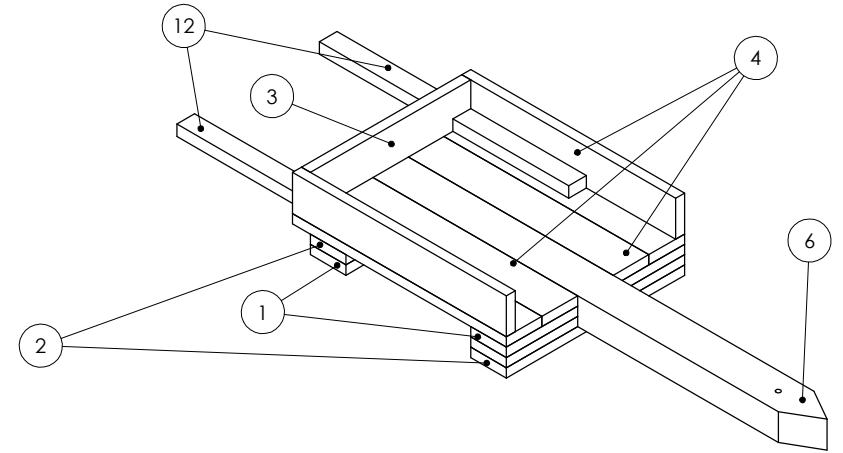

PROPRIETARY AND CONFIDENTIAL  
THE INFORMATION CONTAINED IN THIS  
DRAWING IS THE SOLE PROPERTY OF THE  
DESIGNER. ANY REPRODUCTION IN PART OR  
AS A WHOLE WITHOUT THE WRITTEN  
PERMISSION OF THE DESIGNER IS PROHIBITED.

**kartbuilding.net**



TITLE: CHASSIS #2

MATERIAL AS SPECIFIED

DATE: 26/02/2011

FILE NAME: Main-Wooden-Kart-Inches-

SIZE: A4

REV. 1

SCALE: 1:20

DESIGNER: STEPHEN BURKE

SHEET 8 OF 21





### MAIN CHASSIS #3

The stages in putting the chassis together can be seen below.

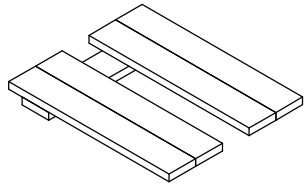

Step 1.

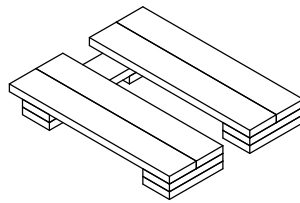

Step 2.

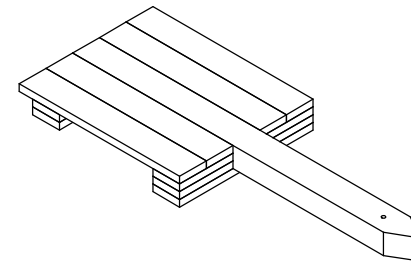

Step 3.

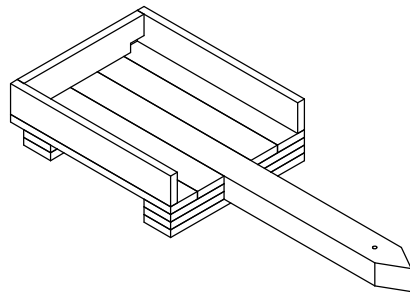

Step 4.

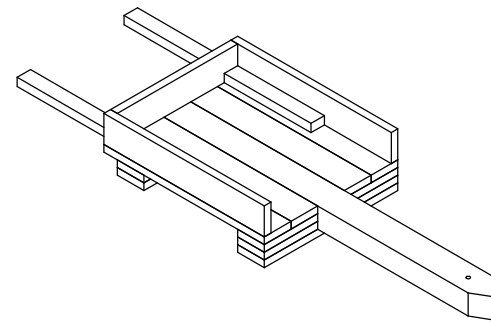

Step 5.

PROPRIETARY AND CONFIDENTIAL  
THE INFORMATION CONTAINED IN THIS  
DRAWING IS THE SOLE PROPERTY OF THE  
DESIGNER. ANY REPRODUCTION IN PART OR  
AS A WHOLE WITHOUT THE WRITTEN  
PERMISSION OF THE DESIGNER IS PROHIBITED.



**kartbuilding.net**



TITLE: CHASSIS #3

MATERIAL AS SPECIFIED

DATE: 26/02/2011

FILE NAME: Main-Wooden-Kart-Inches-

SIZE: A4

REV. 1

SCALE: 1:20

DESIGNER: STEPHEN BURKE

SHEET 9 OF 21

# FRONT AXLE ASSEMBLY #1

All the parts required for the Front Axle Assembly can be seen below. To see the quantities of parts required, compare the labelled numbers to SHEET 4.

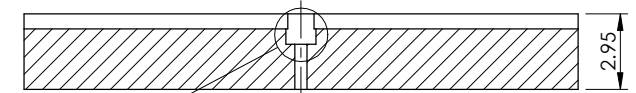
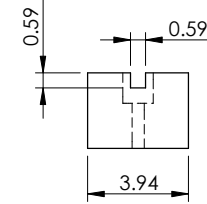
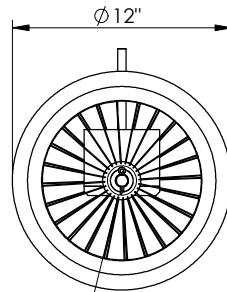
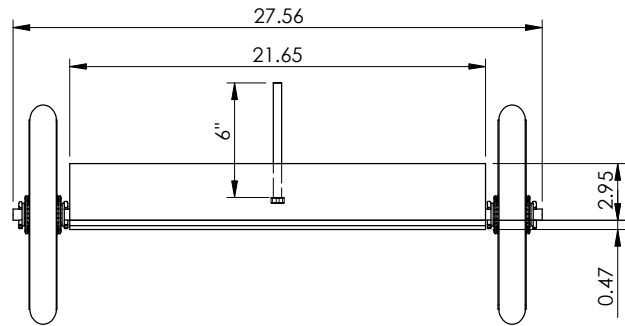
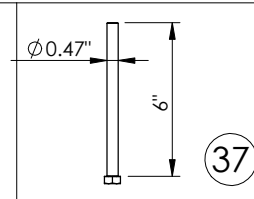
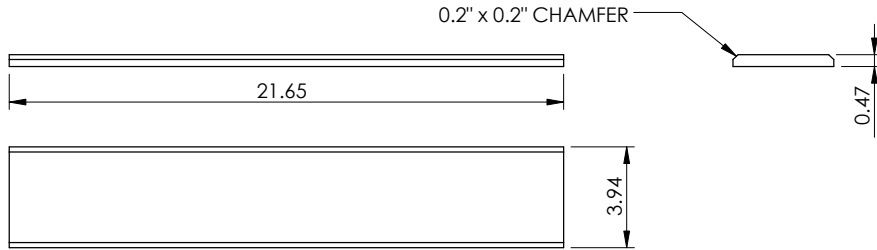
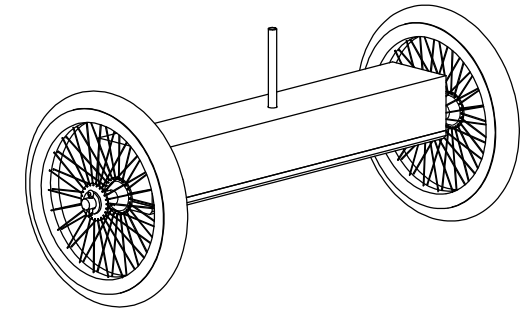

SECTION D-D  
SCALE 1 : 7.5

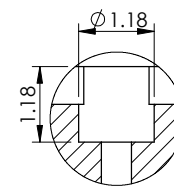

DETAIL C  
SCALE 1 : 3

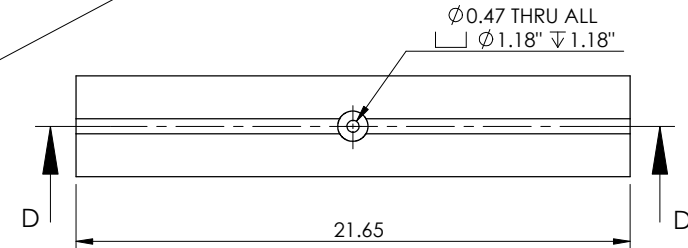

5

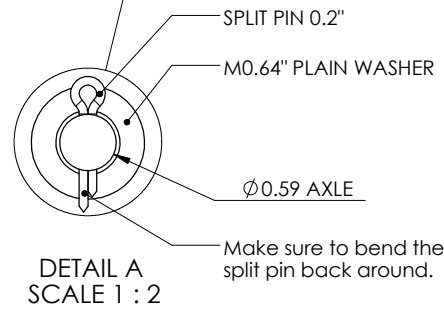
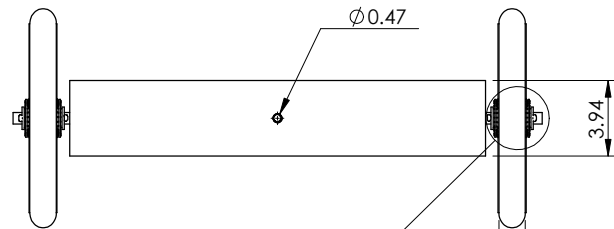

DETAIL A  
SCALE 1 : 2

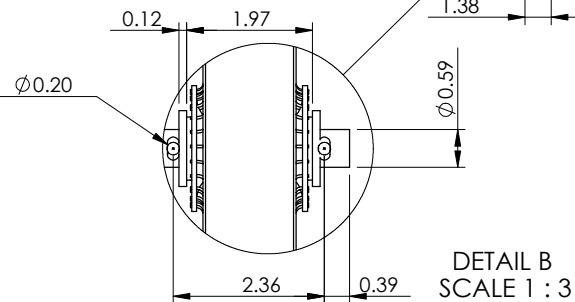

DETAIL B  
SCALE 1 : 3

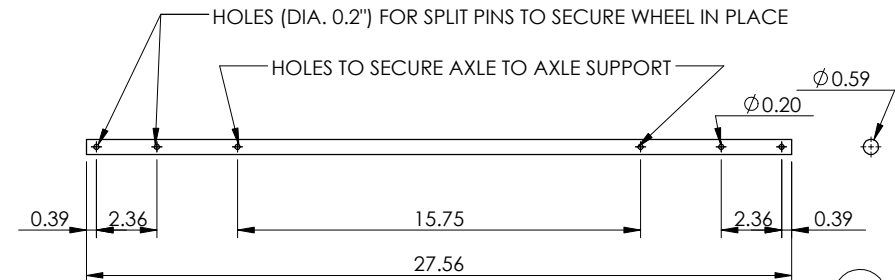

16

PROPRIETARY AND CONFIDENTIAL  
THE INFORMATION CONTAINED IN THIS  
DRAWING IS THE SOLE PROPERTY OF THE  
DESIGNER. ANY REPRODUCTION IN PART OR  
AS A WHOLE WITHOUT THE WRITTEN  
PERMISSION OF THE DESIGNER IS PROHIBITED.

kartbuilding.net		
TITLE: FRONT AXLE ASSEMBLY #1		
MATERIAL AS SPECIFIED	DATE: 26/02/2011	
FILE NAME: Main-Wooden-Kart-Inches-	SIZE: A4	REV. 1
SCALE: 1:20	DESIGNER: STEPHEN BURKE	SHEET 10 OF 21

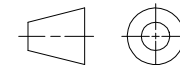

## FRONT AXLE ASSEMBLY #2

The stages in making and assembling the Front Axle Assembly can be seen below.

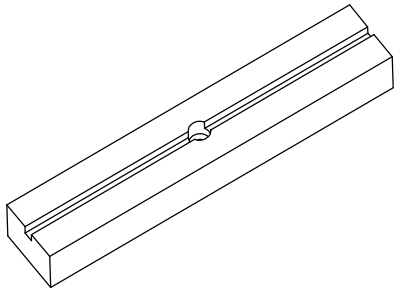

**Step 1:**  
Cut a 0.59" x 0.59" slot in the Front Axle Support. Do this by cutting 3-4 cuts along the length of the piece using a Hand Saw or electric saw (see SHEET 5) and use a chisel to clean up and fully remove the slot. Finally drill a hole 0.48" for the Bolt, and a 1.2" hole 1.2" deep to take the M0.48" Bolt to attach to the main chassis.

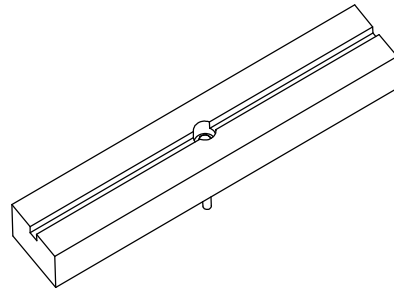

**Step 2:**  
Insert the M0.48" Bolt into the hole which was drilled previously. Make sure the head of the bolt goes below the 0.6" slot in the Front Axle Support.

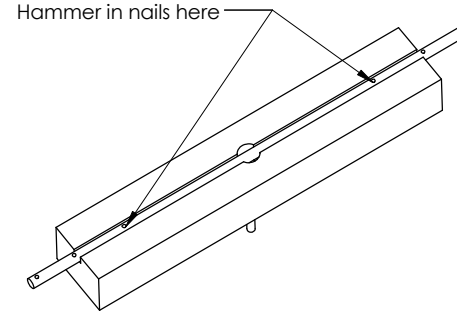

**Step 3:**  
Sit the Axle in place. Secure the Axle in the slot, by hammering nails into the 2 holes in the axle. This prevents the Axle from moving side to side in the slot.

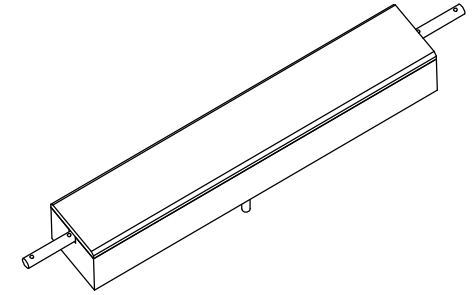

**Step 4:**  
Fix the Front Axle Support Cover in position, and use nails to secure in place.

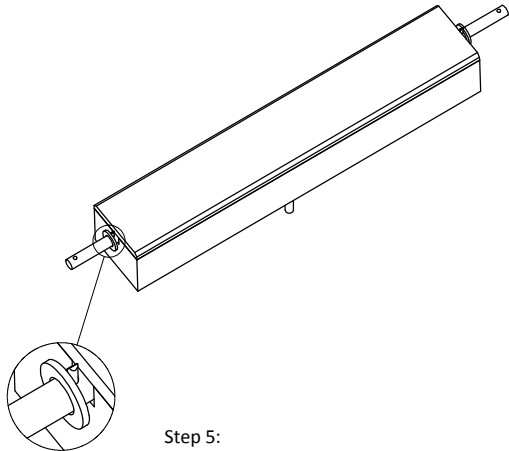

DETAIL E  
SCALE 1 : 3

**Step 5:**  
Insert a Split Pin (or a nail and bend the end of it so it will not come out) and a washer on either side of the Axle.

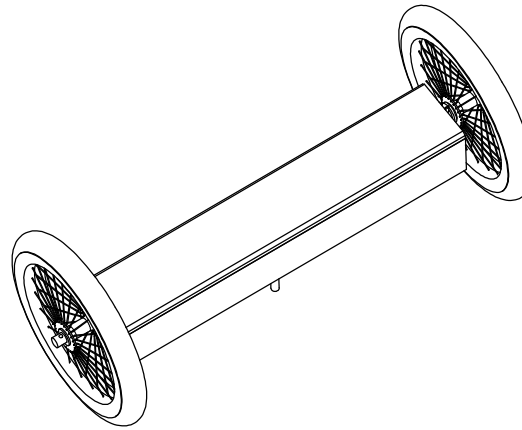

**Step 6:**  
Place the two wheels onto the ends of the Axle. Make sure to apply plenty of grease and oil so the wheels rotate smoothly. Depending on the size of the hole in the middle of the spoked wheel, there are two options:

1. Obtain a 0.6" Drill bit and increase the size of the hole in the Wheel
2. Use a smaller diameter Axle (only advisable for the Front Axle)
3. File / Grind down the ends of the axle so the wheel can fit.

DETAIL F  
SCALE 1 : 3

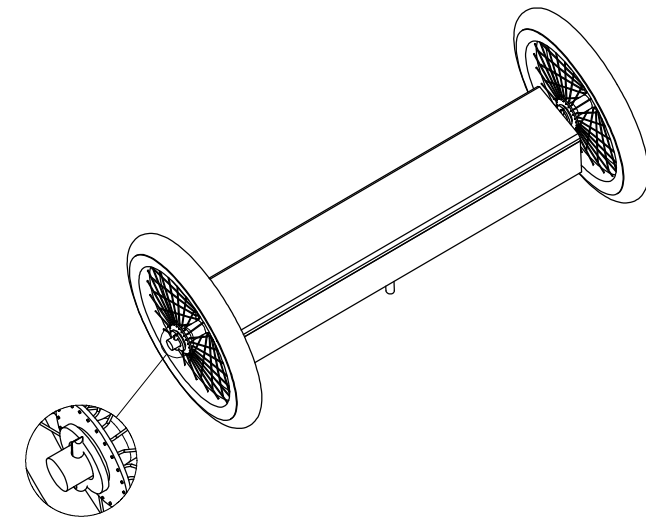

**Step 7:**  
Insert the final washer and split pins (or nails) into position on either end of the Axle. The Front Axle Assembly is now complete.

<small>PROPRIETARY AND CONFIDENTIAL THE INFORMATION CONTAINED IN THIS DRAWING IS THE SOLE PROPERTY OF THE DESIGNER. ANY REPRODUCTION IN PART OR AS A WHOLE WITHOUT THE WRITTEN PERMISSION OF THE DESIGNER IS PROHIBITED.</small>					
<b>TITLE: FRONT AXLE ASSEMBLY #2</b>					
MATERIAL AS SPECIFIED				DATE: 26/02/2011	
FILE NAME: Main-Wooden-Kart-Inches-			SIZE: A4	REV. 1	
SCALE: 1:20	DESIGNER: STEPHEN BURKE			SHEET 11 OF 21	

# REAR AXLE ASSEMBLY #1

All the parts required for the Rear Axle Assembly can be seen below. To see the quantities of parts required, compare the labelled numbers to SHEET 4.

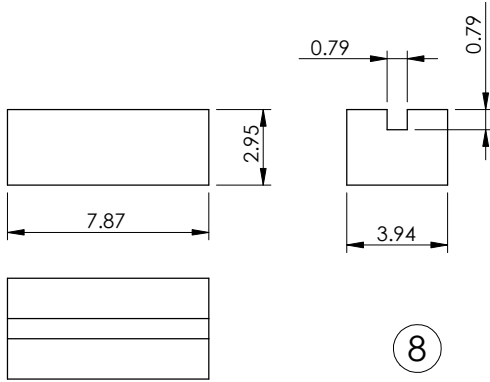

8

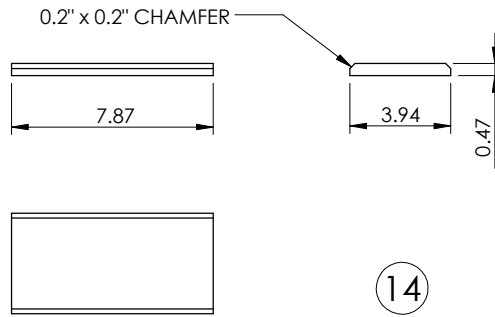

14

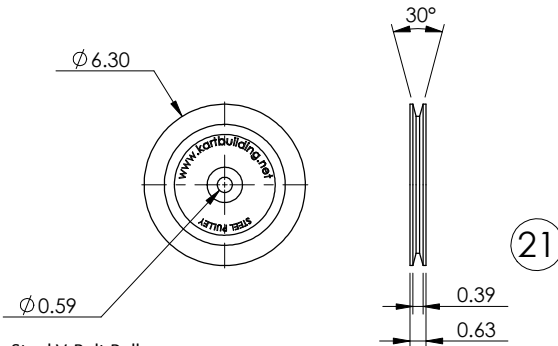
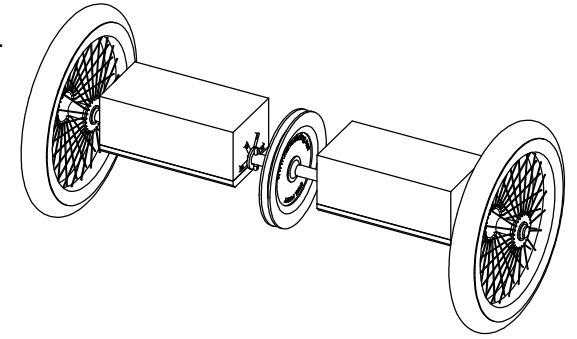

21

**Steel V-Belt Pulley:**  
The reason a steel pulley is best, is because this can be easily welded to the metal rear axle. The size of this pulley wheel should be at least 5 times the size of the small pulley wheel on the engine.  
If a Steel V-Belt Pulley cannot be obtained, and only an aluminium one is available, then see SHEET 14.

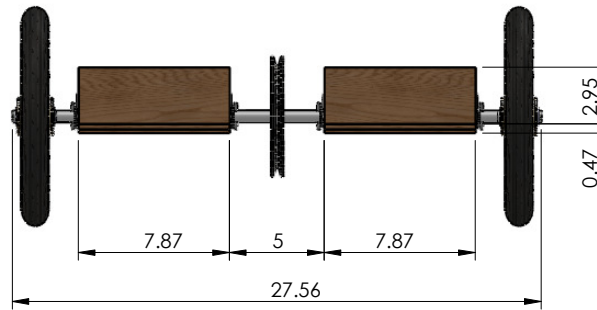

**Rear Axle Assembly:**  
This is a "Live Axle" arrangement. The entire Axle spins. The steel pulley is welded to the Axle. The two wheels are also welded to the Axle. The Rear Axle Supports will be attached to the main chassis. If the Spoked Wheels do not have a metal hub, or cannot be welded to the rear Axle, see SHEET 14.

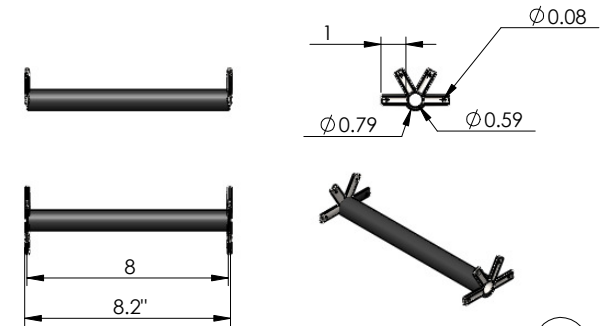

25

**Rear Axle Bushing:**  
This piece is made from a 10" long piece of Pipe/Tube with outside diameter of 0.8" and inside diameter of 0.6" (wall thickness of 0.1"). Slits are made 1" in the end of the Pipe with a "hacksaw" (SHEET 5), and the resulting pieces are bent outwards using a pliers. Two of the bottom pieces are removed. These tabs/pieces allow the tube to be nailed/secured to the Rear Axle Support and prevent them from spinning / rotating inside the support.

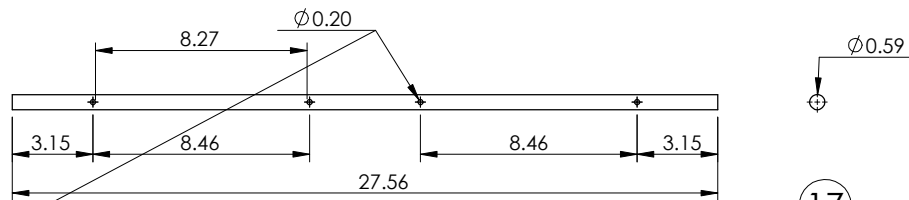

17

**Rear Axle:**  
8.6" is the distance between the center of the two holes. The holes are 0.2" Diameter, so the closest distance between the two holes is 8.4". The overall length of the Rear Axle Bushing is 8.2". Two washers each of 0.1" thickness takes up the distance, making for a perfect fit.

<p><b>PROPRIETARY AND CONFIDENTIAL</b> THE INFORMATION CONTAINED IN THIS DRAWING IS THE SOLE PROPERTY OF THE DESIGNER. ANY REPRODUCTION IN PART OR AS A WHOLE WITHOUT THE WRITTEN PERMISSION OF THE DESIGNER IS PROHIBITED.</p>			
<p><b>kartbuilding.net</b></p>		<p><b>KARTBUILDING</b></p>	
<p>TITLE: <b>REAR AXLE ASSEMBLY #1</b></p>			
<p>MATERIAL AS SPECIFIED</p>		<p>DATE: 26/02/2011</p>	
<p>FILE NAME: Main-Wooden-Kart-Inches-</p>		<p>SIZE: A4</p>	<p>REV. 1</p>
<p>SCALE: 1:20</p>	<p>DESIGNER: STEPHEN BURKE</p>		<p>SHEET 12 OF 21</p>



## REAR AXLE ASSEMBLY #2

The stages in making and assembling the Rear Axle Assembly can be seen below.

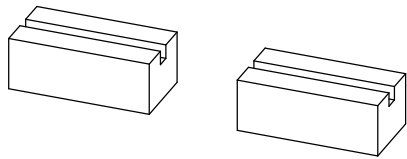

Step 1:  
Cut a 0.8" x 0.8" slot in the Rear Axle Supports. Do this by cutting 3-4 cuts along the length of the piece using a Hand Saw or electric saw (see SHEET 5) and use a chisel to clean up and fully remove the slot.

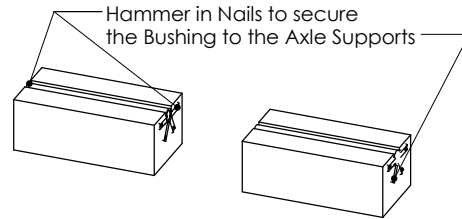

Step 2:  
Insert the Rear Axle Bushings into the slots. Hammer nails in the ends of the Axle Bushings as shown above.

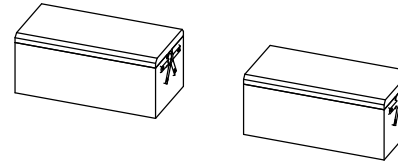

Step 3:  
Nail the Rear Axle Support Covers in place using ordinary round wire nails.

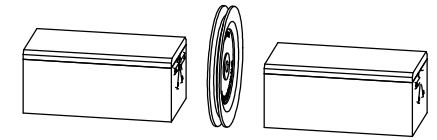

Step 4:  
Line up the Steel Pulley in Place.

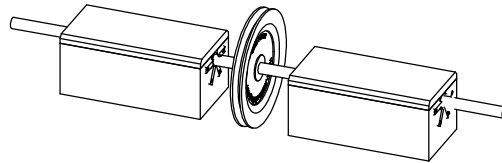

Step 5:  
Insert the Rear Axle through the Bushings and Steel Pulley.

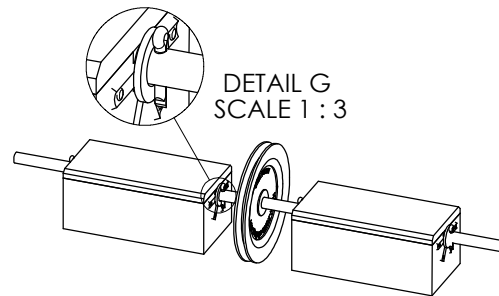

Step 6:  
Apply grease and oil inside the Bushings, allowing them to rotate freely on the axle. Insert Washers and Split Pins to prevent the Axle supports from moving side to side.

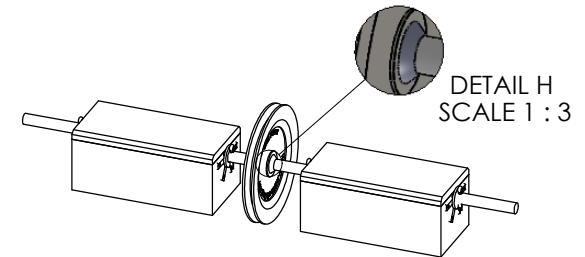

Step 7:  
Weld the Steel Pulley Wheel to the Rear Axle. If you don't have a welder, take the Rear Axle Assembly to an Engineering company, and get them to do the welding for you. If you don't have a steel pulley wheel, see SHEET 14.

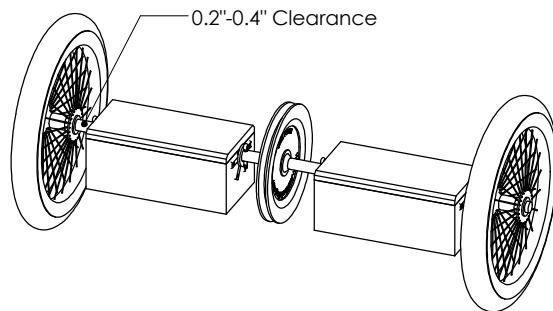

Step 8:  
Fit the Spoked Wheels onto the ends of the Axle, leaving 0.2" - 0.4" clearance between the split pins.  
Depending on the size of the hole in the middle of the spoked wheel, there are two options:  
1. Obtain a 0.6" Drill bit and increase the size of the hole in the Wheel  
2. File / Grind down the ends of the axle so the wheel can fit.

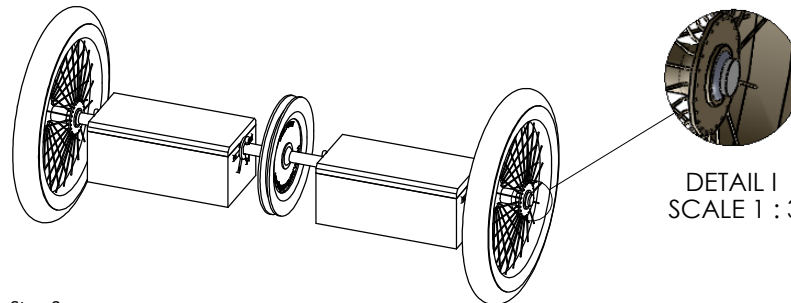

Step 9:  
Weld the Spoked Wheels to the Axle. If you don't have a welder, take the Rear Axle Assembly to an Engineering company, and get them to do the welding for you. If the Spoked Wheels do not have a metal hub, or cannot be welded to the rear Axle, see SHEET 14.

<p><b>PROPRIETARY AND CONFIDENTIAL</b> THE INFORMATION CONTAINED IN THIS DRAWING IS THE SOLE PROPERTY OF THE DESIGNER. ANY REPRODUCTION IN PART OR AS A WHOLE WITHOUT THE WRITTEN PERMISSION OF THE DESIGNER IS PROHIBITED.</p>				<p><b>kartbuilding.net</b> </p>	
<p>TITLE: <b>REAR AXLE ASSEMBLY #2</b></p>					
<p>MATERIAL AS SPECIFIED</p>				<p>DATE: 26/02/2011</p>	
<p>FILE NAME: Main-Wooden-Kart-Inches-</p>			<p>SIZE: A4</p>	<p>REV. 1</p>	
<p>SCALE: 1:20</p>		<p>DESIGNER: STEPHEN BURKE</p>			<p>SHEET 13 OF 21</p>

### REAR AXLE ASSEMBLY #3

As this Rear Axle is "live", the entire axle rotates, along with the Pulley Wheel and the two Spoked Wheels. (As opposed to a dead axle, where only the wheels spin on the fixed axle.) Therefore, both the pulley wheel and the two rear wheels must be fixed or welded to the rear Axle. The easiest and quickest method to fix the Spoked Wheels and Pulley to the Axle is to weld them. This requires that the Pulley Wheel and Spoked Wheels have metal / steel hubs which can be welded to the metal Axle. It also requires the use (or borrowing, or asking someone) of a welder.

It may be possible however to secure the pulley wheel and the two spoked wheels to the Rear Axle without the use of a welder. While it is advised that a wheel with a metal hub/center is used, on a last resort it may be possible to use a wheel which has a hard plastic hub, and to secure this to the Rear Axle. This page describes how to do this.

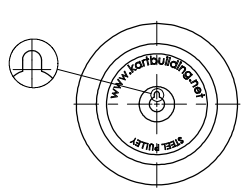
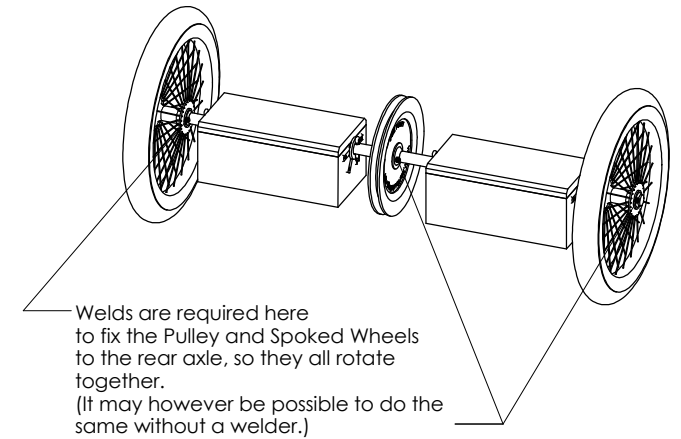

Step 1:  
Drill a 0.2" Hole through the Pulley close to the center hole. Clean and file / grind square.

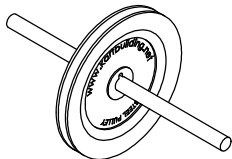

Step 2:  
Insert the Axle into the center hole.

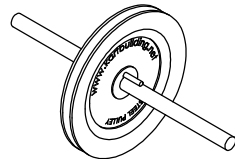

Step 3:  
Insert a M0.2" Bolt x 2" Long (with its head cut off) into the small 0.2" hole drilled in Step 1.

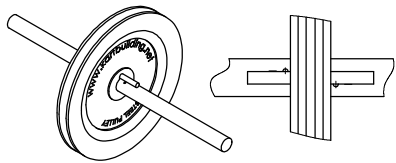

Step 4:  
Drill 2 Holes of diameter 0.08" on either side of the pulley.

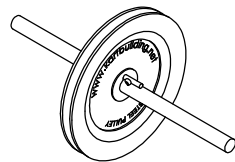

Step 5:  
Insert 2 Split Pins. These will prevent the pulley wheel from rotating, and also stop the pulley from moving side to side.

Securing the Pulley to the Axle

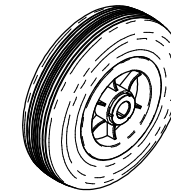

Step 1:  
Wheel with a plastic hub.

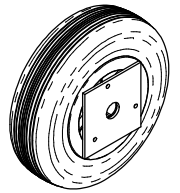

Step 2:  
Obtain 2 pieces of 0.08" sheet steel. Sandwich the 2 plates on either side of the wheel. Drill 3 holes through the steel plates and the plastic hub.

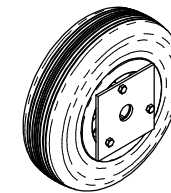

Step 3:  
Insert 3 bolts which are long enough to secure the 2 plates (one on either side of the wheel) to the plastic hub.

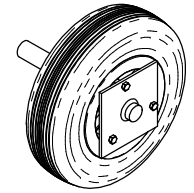

Step 4:  
Insert the metal axle. In this case the 2 steel plates are welded to the rear axle. If no welder is available then a similar method used in securing the pulley to the axle (as described above), could be used here.

Securing a Wheel with a Plastic middle / hub to the Rear Axle.

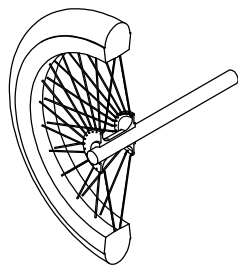

Step 1:  
Place Axle through the center of the wheel. (Wheel cut in half above for clarity)

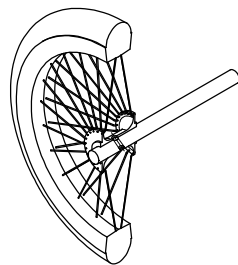

Step 2:  
Drill a 0.2" diameter hole through the center of the wheel and axle together.

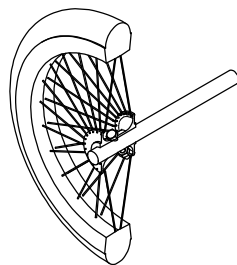

Step 3:  
Insert a 0.2" Bolt into the hole. Tighten a nyloc locknut in place to prevent it from loosening.

Securing the Wheels to the Axle

PROPRIETARY AND CONFIDENTIAL  
THE INFORMATION CONTAINED IN THIS DRAWING IS THE SOLE PROPERTY OF THE DESIGNER. ANY REPRODUCTION IN PART OR AS A WHOLE WITHOUT THE WRITTEN PERMISSION OF THE DESIGNER IS PROHIBITED.

kartbuilding.net

TITLE: REAR AXLE ASSEMBLY #3

MATERIAL AS SPECIFIED DATE: 26/02/2011

FILE NAME: Main-Wooden-Kart-Inches- SIZE: A4 REV. 1

SCALE: 1:20 DESIGNER: STEPHEN BURKE SHEET 14 OF 21

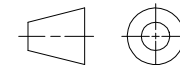

## ASSEMBLY OF THE ROLLING CHASSIS

With the Chassis, Front Axle Assembly, and Rear Axle Assembly completed, we need to put these together to form a "rolling chassis".

Make sure to place the v-belt on the rear axle, before screwing the rear axle to the Chassis (v-belt not shown below). When bolting the Front Axle Assembly to the chassis, make sure that the front axle can rotate right and left.

At this stage, you should have a complete rolling chassis, which could be used as a "push kart" or for a downhill racer.

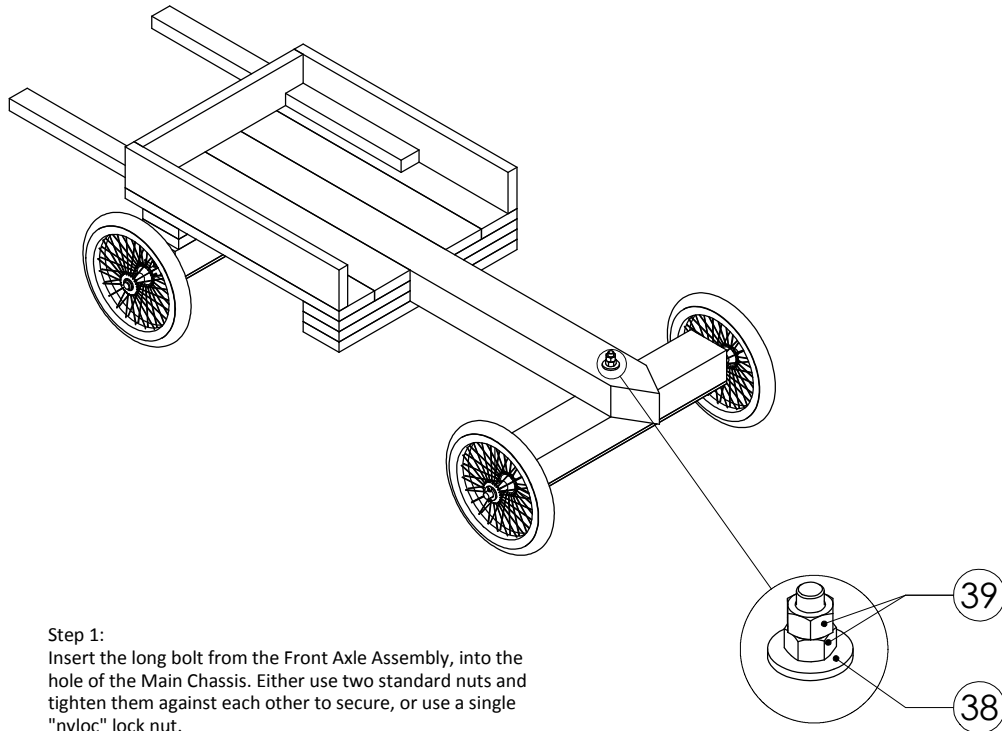

Step 1:  
Insert the long bolt from the Front Axle Assembly, into the hole of the Main Chassis. Either use two standard nuts and tighten them against each other to secure, or use a single "nyloc" lock nut.  
Make sure that the Front Axle can turn left and right.

DETAIL J  
SCALE 1 : 3

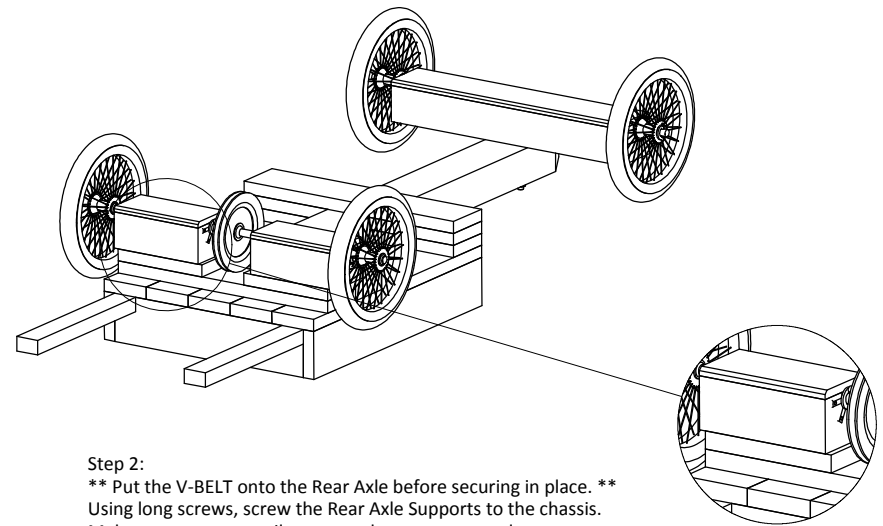

Step 2:  
\*\* Put the V-BELT onto the Rear Axle before securing in place. \*\*  
Using long screws, screw the Rear Axle Supports to the chassis.  
Make sure you can easily remove these screws at a later stage to allow for a replacement v-belt.

DETAIL K  
SCALE 1 : 10

<p><b>PROPRIETARY AND CONFIDENTIAL</b> THE INFORMATION CONTAINED IN THIS DRAWING IS THE SOLE PROPERTY OF THE DESIGNER. ANY REPRODUCTION IN PART OR AS A WHOLE WITHOUT THE WRITTEN PERMISSION OF THE DESIGNER IS PROHIBITED.</p>		<p><b>kartbuilding.net</b> </p>	
<p>TITLE: <b>ROLLING CHASSIS</b></p>			
<p>MATERIAL AS SPECIFIED</p>		<p>DATE: 26/02/2011</p>	
<p>FILE NAME: Main-Wooden-Kart-Inches-</p>	<p>SIZE: A4</p>	<p>REV. 1</p>	
<p>SCALE: 1:20</p>	<p>DESIGNER: STEPHEN BURKE</p>		<p>SHEET 15 OF 21</p>

## MOUNTING THE LAWNMOWER ENGINE TO THE CHASSIS #1

With the rolling chassis now complete, it is time to attach the lawnmower engine, and connect up the V belt.

The first step is to secure the engine to the mounting base. This mounting base is then in turn screwed to the Rear Engine Support Arms.

While it is possible to directly connect and tension the V-Belt between the engine and rear axle at this point, and then to screw the mounting base in position, this direct drive setup means that once the engine is started, the kart would take off. (The author tried this once, and had it working. The kart was raised up on blocks, the engine started, turning the wheels, and then the kart was slowly lowered off the blocks onto the ground, and off the kart would go. To stop the kart, the engine had to be stopped.) Instead, this set of plans show how an "idler" pulley is used to apply tension to the drive belt to act like a clutch.

As a result when screwing the mounting base to the rear support arms, make sure that the v-belt is loose enough not to grip the pulley wheels, but tight enough as not to fall off the engine pulley and onto the ground.

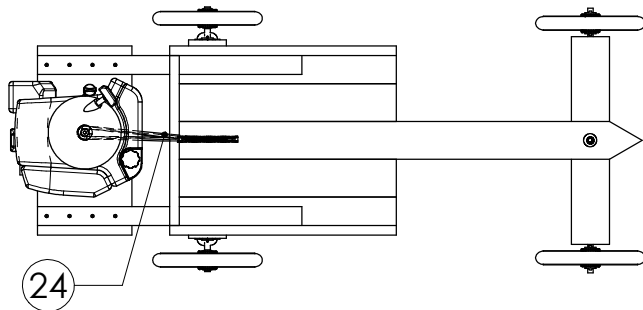
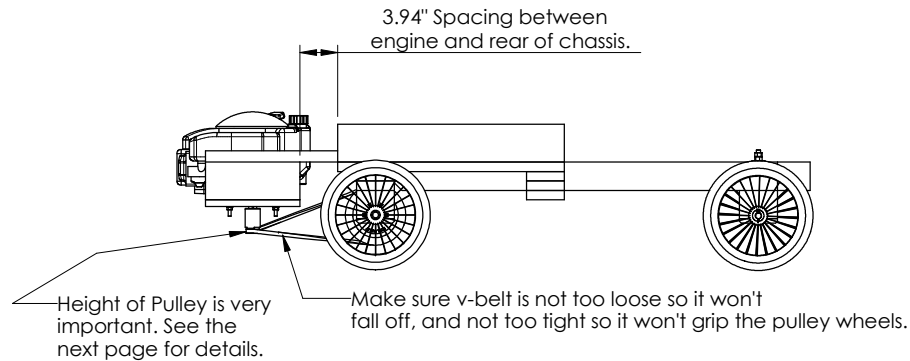

V-Belt and Pulleys shown for clarity. The alignment of the two pulleys is important (See next page).

The Lawnmower engine is first secured to a piece of 1" thick plywood, 20" x 10", using 4 bolts. There should already be bolt holes in the engine you can use. Make sure to drill corresponding holes in the plywood to match up with the holes in the engine. Typically M0.32" Bolts 2" Long will suffice. Use a washer and 'nyloc' lock nut to secure. Make sure to cut a single large hole in the middle to allow the engine's output to shaft to protrude out.

For reasons which will be discussed later, an "Engine Spacer" is required. This is a large piece of timber/wood, 4"x3"x10" which is screwed to either side of the plywood as shown. It is better to use wood screws in this case instead of nails for better security (wood screws not shown on the right).

The lawnmower engine should now be secured to this plywood base, with the drive-shaft pointing out the bottom. Further details on securing the small pulley wheel to the engine drive shaft is outlined on the next page.

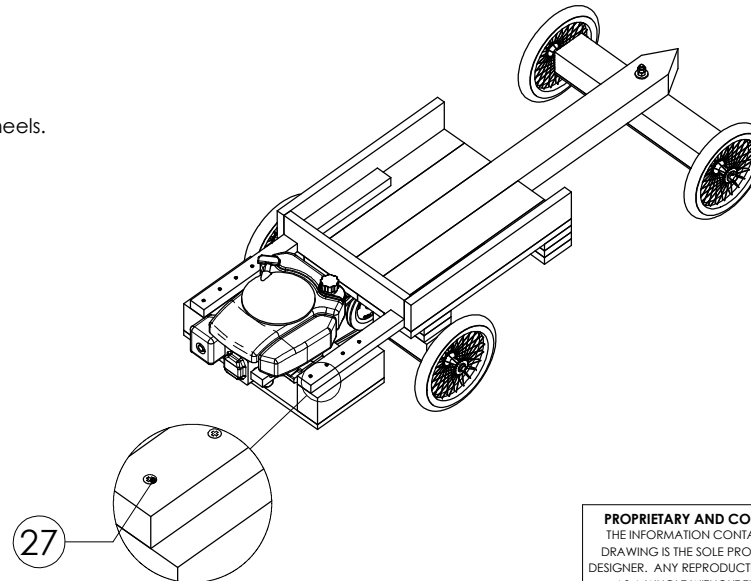
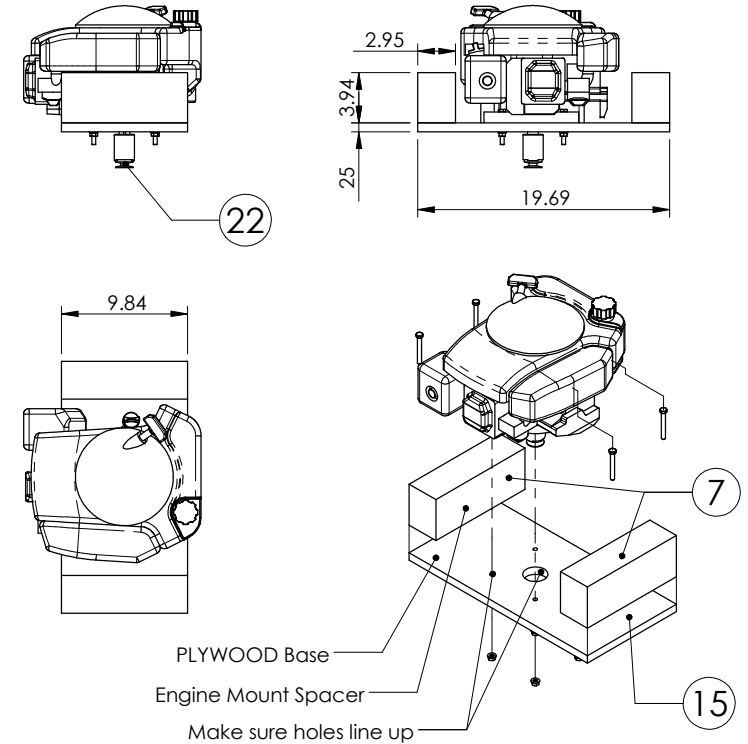

The Engine Mounting is screwed to the two "Engine Support Arms" at the rear.

DETAIL L  
SCALE 1 : 5

PROPRIETARY AND CONFIDENTIAL  
THE INFORMATION CONTAINED IN THIS  
DRAWING IS THE SOLE PROPERTY OF THE  
DESIGNER. ANY REPRODUCTION IN PART OR  
AS A WHOLE WITHOUT THE WRITTEN  
PERMISSION OF THE DESIGNER IS PROHIBITED.

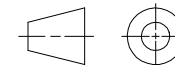

kartbuilding.net 

TITLE: ENGINE MOUNTING #1

MATERIAL AS SPECIFIED DATE: 26/02/2011

FILE NAME: Main-Wooden-Kart-Inches- SIZE: A4 REV. 1

SCALE: 1:20 DESIGNER: STEPHEN BURKE SHEET 16 OF 21



## MOUNTING THE LAWNMOWER ENGINE TO THE CHASSIS #2

Before the lawnmower engine can be mounted to the kart, the small driving pulley wheel needs to be attached securely to the output shaft of the engine. Depending on the make and model of lawnmower engine, slight changes may be required. This page shows the modifications made to a small aluminium pulley wheel for a Briggs and Stratton engine.

Once the pulley wheel is securely attached to the engine's output shaft, the next key step is to align the engine up with the rear axle pulley wheel. Although the V-belt will twist through 90 degrees, and although it shouldn't come off, there are a few notes to remember, which will make sure that the v-belt will not come off and not wear excessively. See below for further details. (The front end of the Kart has been removed for clarity).

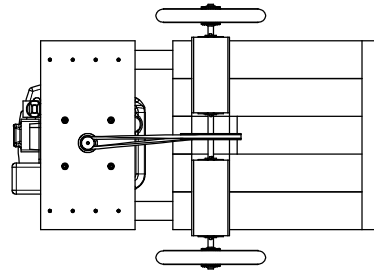

BOTTOM VIEW

The distance (D1) as shown, should be minimised as much as possible. This is because: In order for the kart to move forwards, the v-belt coming from the bottom of the large pulley on the Rear Axle must be pulled.

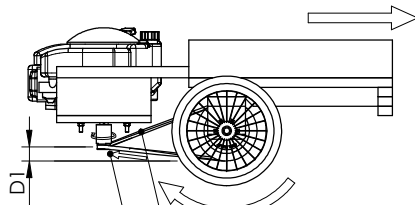

Return feed of the v-belt.

Pull Direction of the v-belt. Important to have this as straight as possible to prevent the belt from coming off.

From the Top View, the engine rotates clockwise.

Pull Direction. This needs to be as straight as possible.

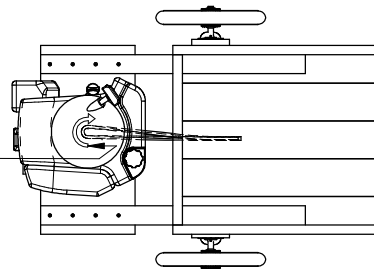

TOP VIEW

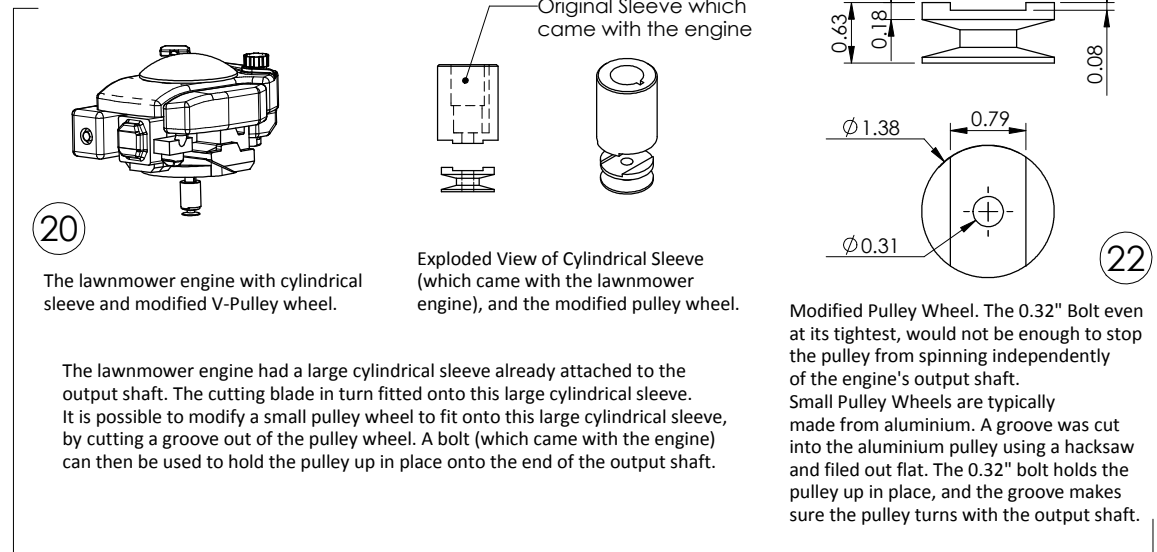

While it is not critical to have the alignment of the v-belt and pulley wheels 100%, (because the belt is V shaped, it will stay on the pulley wheels as it moves) if you find that your v-belt is coming off too regularly, then check your setup with the details on this page.

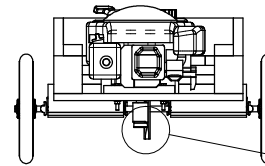

END VIEW

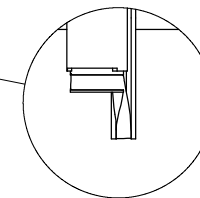

In order for the kart to move forward, the bottom of the large pulley wheel must be "pulled". Keep the "pull" direction of the v-belt as straight as possible.

DETAIL M  
SCALE 1 : 5

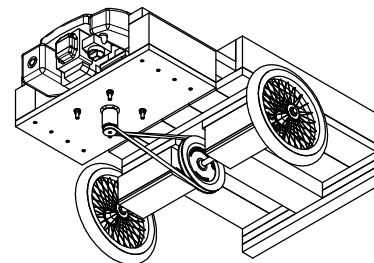

VIEW UNDERNEATH THE KART

PROPRIETARY AND CONFIDENTIAL  
THE INFORMATION CONTAINED IN THIS DRAWING IS THE SOLE PROPERTY OF THE DESIGNER. ANY REPRODUCTION IN PART OR AS A WHOLE WITHOUT THE WRITTEN PERMISSION OF THE DESIGNER IS PROHIBITED.

kartbuilding.net



TITLE: ENGINE MOUNTING #2

MATERIAL AS SPECIFIED DATE: 26/02/2011

FILE NAME: Main-Wooden-Kart-Inches- SIZE: A4 REV. 1

SCALE: 1:20 DESIGNER: STEPHEN BURKE SHEET 17 OF 21

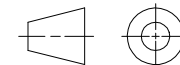

# BELT TENSIONER / CLUTCH

It was mentioned on "Engine Mounting #1" how it would be possible to create a "direct drive" where the belt was left tensioned permanently and the engine mount board screwed into position. This means that once the engine started, the kart would take off. It also meant that in order to stop the kart, the engine had to be stopped.

This page outlines how a 3rd Pulley Wheel can be used as a "Belt Tensioner". A 3rd Pulley wheel is mounted on a lever which can be moved away from, or against the v-belt. When this 3rd pulley wheel moves against the v-belt, it takes up the slack in the belt, tensions it, and causes the v-belt to grip the pulleys on the engine and the rear axle, power is transferred and the kart moves off. (The front of the kart is removed below for clarity.)

The 3rd Pulley (Idler) must move up and out against the "return path" of the v-belt, as shown. When the driver pulls the lever upwards, it causes the idler pulley to pull up against the v-belt, tension it, and causes the belt to grip the engine and rear axle pulleys, and move the kart forward.

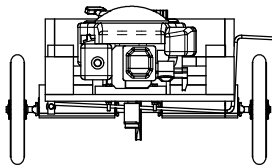
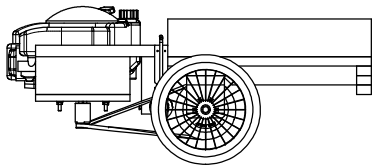
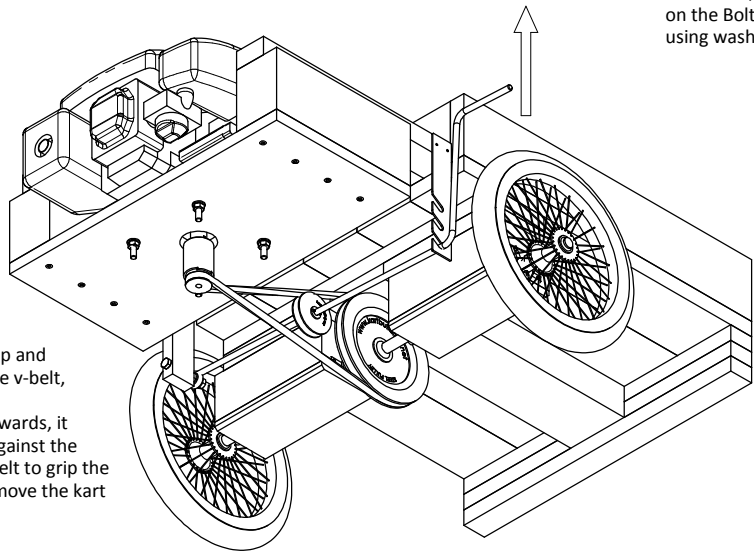

The 0.32" Bar is bent to shape at the end, to allow it to hinge on the Bolt, and is kept in place using washers and lock nuts.

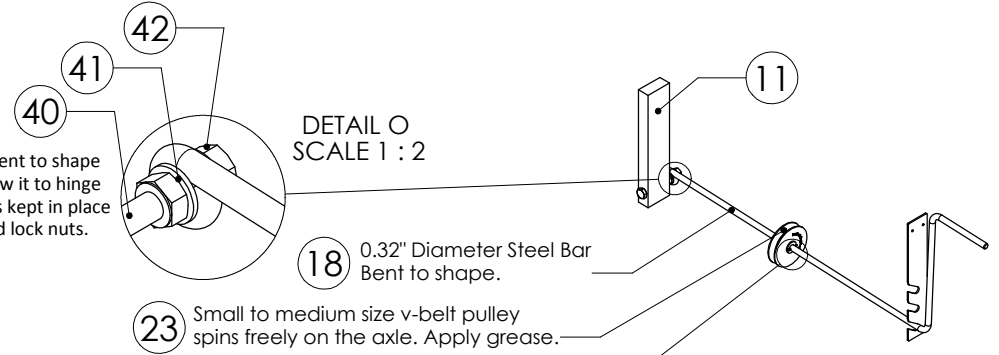

DETAIL O  
SCALE 1 : 2

18 0.32" Diameter Steel Bar Bent to shape.

23 Small to medium size v-belt pulley spins freely on the axle. Apply grease.

DETAIL N  
SCALE 1 : 2

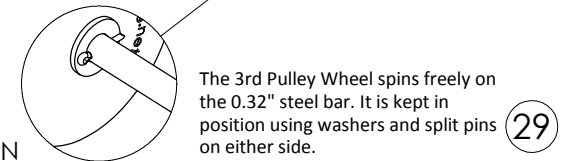

The 3rd Pulley Wheel spins freely on the 0.32" steel bar. It is kept in position using washers and split pins on either side.

Belt Tensioner Keeper  
This piece is easiest made from 0.08" steel plate. Drill three 0.4" Holes, and using a Hacksaw remove the rest of the material to form angled slots.

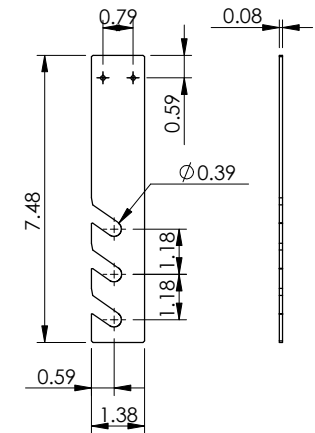

<p>PROPRIETARY AND CONFIDENTIAL THE INFORMATION CONTAINED IN THIS DRAWING IS THE SOLE PROPERTY OF THE DESIGNER. ANY REPRODUCTION IN PART OR AS A WHOLE WITHOUT THE WRITTEN PERMISSION OF THE DESIGNER IS PROHIBITED.</p>	<p><b>kartbuilding.net</b> </p>	
	<p>TITLE: <b>BELT TENSIONER / CLUTCH</b></p>	
	<p>MATERIAL AS SPECIFIED</p>	<p>DATE: 26/02/2011</p>
	<p>FILE NAME: Main-Wooden-Kart-Inches-</p>	<p>SIZE: A4</p>
<p>SCALE:1:20</p>	<p>DESIGNER: STEPHEN BURKE</p>	<p>SHEET 18 OF 21</p>

## REAR BRAKES

The brakes used on this kart, are taken from an ordinary bicycle. Nowadays there are many different types of brakes used on bicycles. The type used in these plans is a "single pivot side-pull calliper brake" (see: [www.en.wikipedia.org/wiki/Bicycle\\_brake\\_systems](http://www.en.wikipedia.org/wiki/Bicycle_brake_systems)). It would be possible to adapt most types of bicycle brakes to suit. In this case the spoked wheel used in this kart has a similar width to a bicycle wheel, and thus these brakes will suit perfectly. More information may be available on [www.kartbuilding.net](http://www.kartbuilding.net) for other types of brakes.

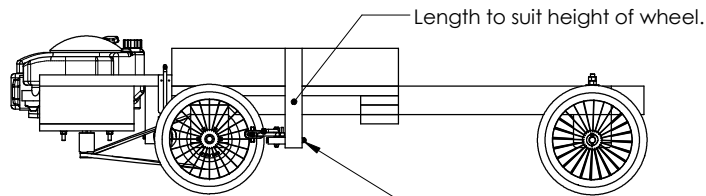
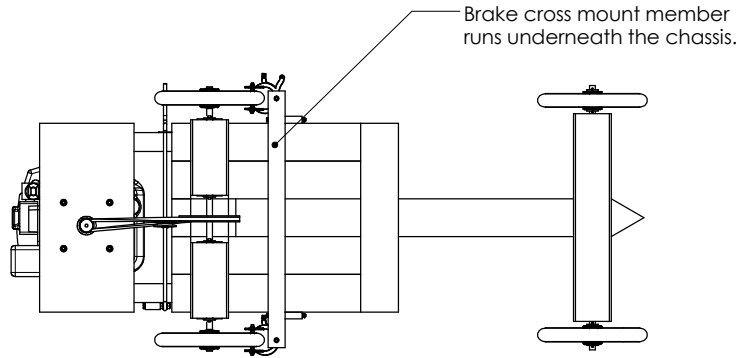

Bolts are used as there are a lot of forces acting on the brake mount members when braking.

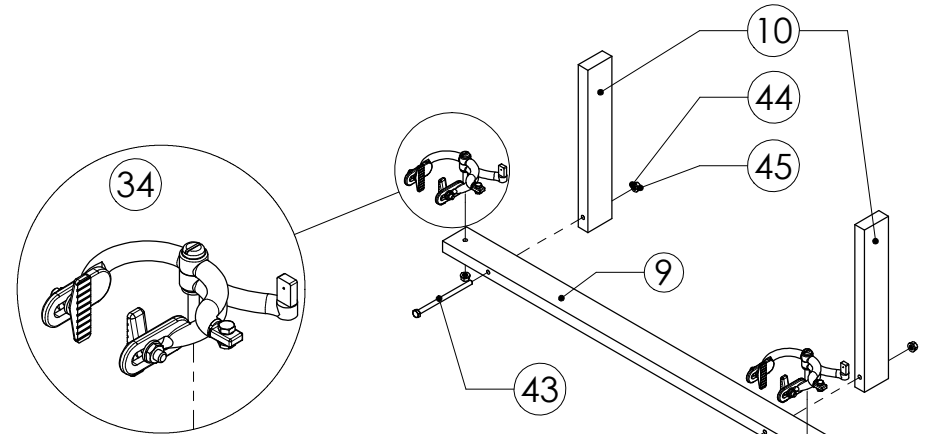
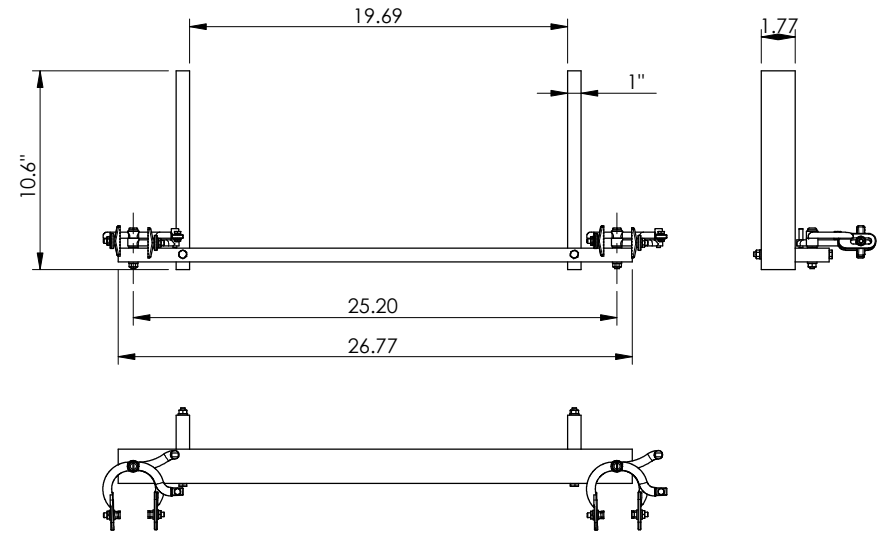
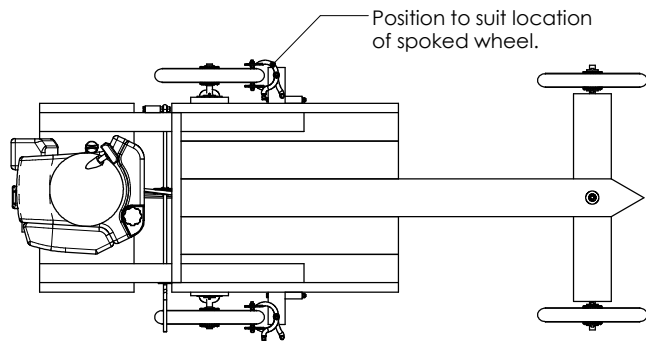

DETAIL P  
SCALE 1 : 4

The complete brake unit from a bicycle.

Pieces of timber/wood, 1.8" x 1" are used to attach the brakes to the wheels in the correct location. Long bolts are used to connect the brakes to these pieces of wood. A drill will be required to drill a hole in the wood, before inserting the bolt.

<p>PROPRIETARY AND CONFIDENTIAL THE INFORMATION CONTAINED IN THIS DRAWING IS THE SOLE PROPERTY OF THE DESIGNER. ANY REPRODUCTION IN PART OR AS A WHOLE WITHOUT THE WRITTEN PERMISSION OF THE DESIGNER IS PROHIBITED.</p>	<p><b>kartbuilding.net</b> </p>	
	<p>TITLE: <b>REAR BRAKES</b></p>	
	<p>MATERIAL AS SPECIFIED</p>	<p>DATE: 26/02/2011</p>
	<p>FILE NAME: Main-Wooden-Kart-Inches-</p>	<p>SIZE: A4</p>
<p>SCALE: 1:20</p>	<p>DESIGNER: STEPHEN BURKE</p>	<p>SHEET 19 OF 21</p>

## Brake and Throttle/Gas Levers & Connections

The brake lever is taken directly off the handlebar of a bicycle. Using a Hacksaw, a portion of the handlebar is cut off, 3 holes are drilled in it, and screwed to the side of the kart chassis.

The throttle / gas lever is taken directly off a Lawnmower. The same cable can be used also. If the cable is not available a bicycle brake cable can be used. If your lawnmower engine does not have a throttle / gas lever at all, then you might have to do without it, and just run the kart at the one speed, using the clutch to start stop the kart. (There may be details on [www.kartbuilding.net](http://www.kartbuilding.net) about how to modify a lawnmower engine to include a throttle control.)

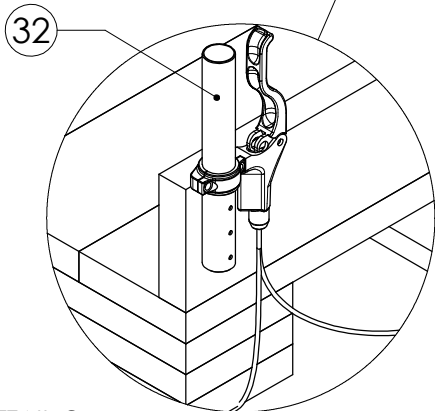
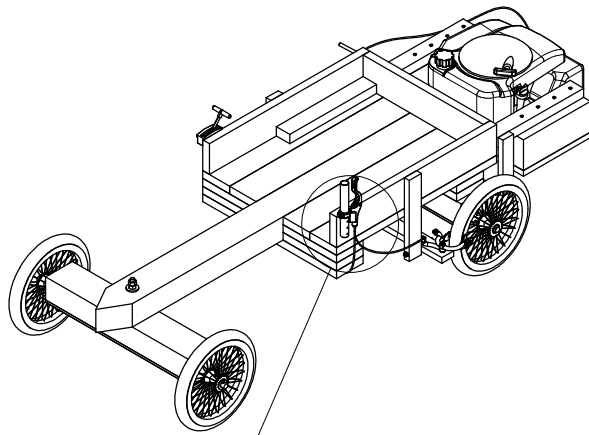

DETAIL Q  
SCALE 1 : 5

Take the brake lever \*and\* the end of the handlebar off a bicycle. Drill 3 holes in the handlebar, and screw it to the side of the chassis as shown.

Two brake cables will have to be inserted into the single brake lever. This will require a little work, and may be more difficult with some brake levers. If need be, use a drill to increase the size of the hole in the brake lever to allow the two brake cables into the housing.

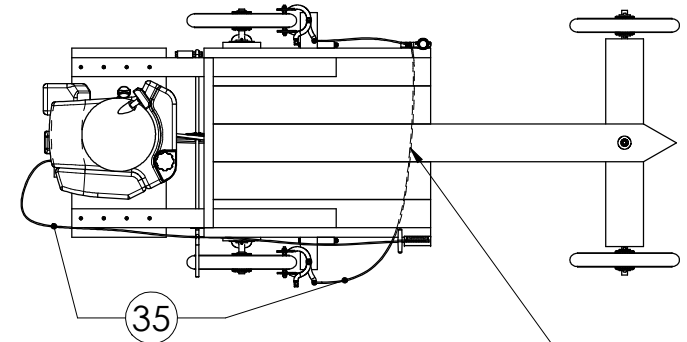

The brake cable is run underneath the chassis. Make sure that the cable does not come too close to the ground. If it does, use a cable tie to secure it.

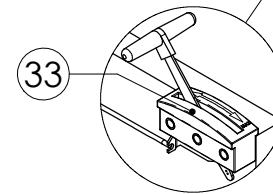
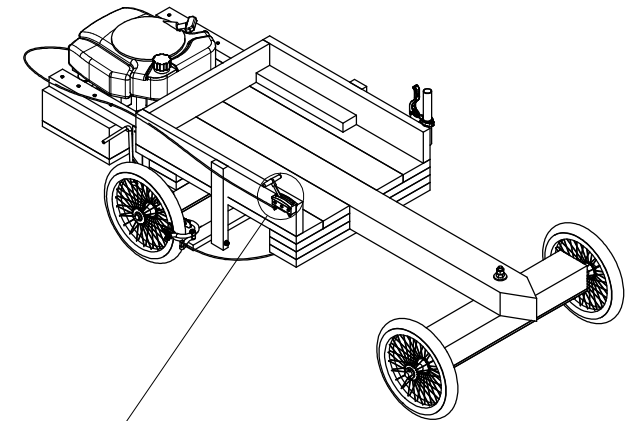

DETAIL R  
SCALE 1 : 5

The accelerator / throttle lever can be taken off a Lawnmower and used directly on the kart. Screw the lever to the side of the chassis and connect up the cable as normal.

PROPRIETARY AND CONFIDENTIAL  
THE INFORMATION CONTAINED IN THIS  
DRAWING IS THE SOLE PROPERTY OF THE  
DESIGNER. ANY REPRODUCTION IN PART OR  
AS A WHOLE WITHOUT THE WRITTEN  
PERMISSION OF THE DESIGNER IS PROHIBITED.

[kartbuilding.net](http://kartbuilding.net)



TITLE: BRAKE & THROTTLE LEVERS

MATERIAL AS SPECIFIED DATE: 26/02/2011

FILE NAME: Main-Wooden-Kart-Inches- SIZE: A4 REV. 1

SCALE: 1:20 DESIGNER: STEPHEN BURKE SHEET 20 OF 21

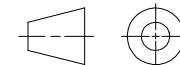



## CONCLUSION TO THE MAIN WOODEN KART POWERED BY A LAWNMOWER ENGINE

The author has attempted to add enough information to these plans to allow anybody to build this kart. If you are looking for any extra dimensions or want a closer look at the kart and all its details, download the 3D interactive model of this kart on the [www.kartbuilding.net](http://www.kartbuilding.net) website.

There is lots of room for improvement and adaptation, and by no means is this a "perfect" design of a lawnmower powered wooden go-kart. It is however a reasonably simple design which the majority of people will be able to make using commonly available parts, materials and tools.

Additional information on this go-kart will be available on the main kartbuilding website at: [www.kartbuilding.net](http://www.kartbuilding.net)

The author would like to hear any comments or suggestions on these plans. Feel free to email [kartbuilding@gmail.com](mailto:kartbuilding@gmail.com) with your thoughts and photos of this and other karts.

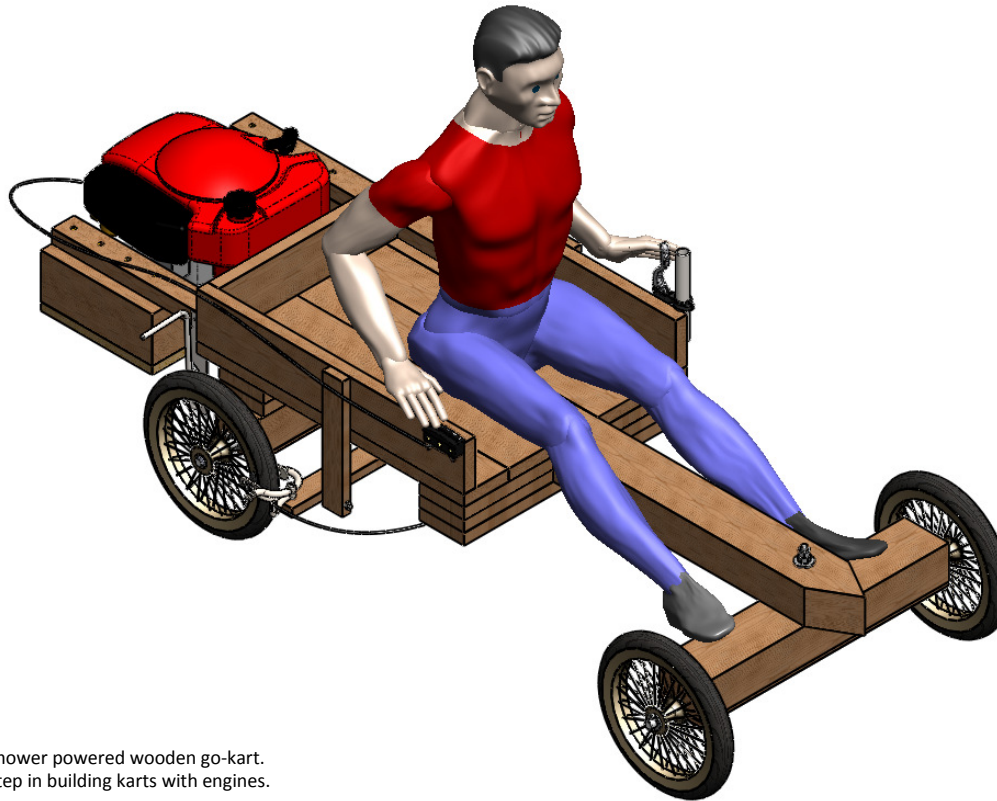

A lawnmower powered wooden go-kart.  
A first step in building karts with engines.

<b>PROPRIETARY AND CONFIDENTIAL</b> THE INFORMATION CONTAINED IN THIS DRAWING IS THE SOLE PROPERTY OF THE DESIGNER. ANY REPRODUCTION IN PART OR AS A WHOLE WITHOUT THE WRITTEN PERMISSION OF THE DESIGNER IS PROHIBITED.			<b>kartbuilding.net</b> 	
TITLE: CONCLUSION				
MATERIAL AS SPECIFIED			DATE: 26/02/2011	
FILE NAME: Main-Wooden-Kart-Inches-		SIZE: A4	REV. 1	
SCALE: 1:20	DESIGNER: STEPHEN BURKE			SHEET 21 OF 21