

## FRONT AXLE ASSEMBLY #2

The stages in making and assembling the Front Axle Assembly can be seen below.

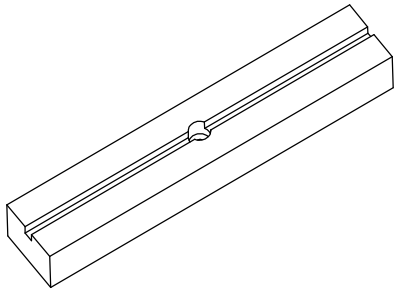

**Step 1:**  
Cut a 15mm x 15mm slot in the Front Axle Support. Do this by cutting 3-4 cuts along the length of the piece using a Hand Saw or electric saw (see SHEET 5) and use a chisel to clean up and fully remove the slot. Finally drill a hole 12mm for the Bolt, and a 30mm hole 30mm deep to take the M12 Bolt to attach to the main chassis.

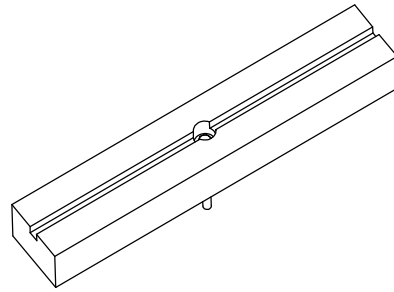

**Step 2:**  
Insert the M12 Bolt into the hole which was drilled previously. Make sure the head of the bolt goes below the 15mm slot in the Front Axle Support.

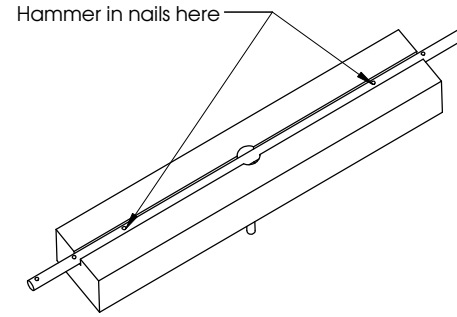

**Step 3:**  
Sit the Axle in place. Secure the Axle in the slot, by hammering nails into the 2 holes in the axle. This prevents the Axle from moving side to side in the slot.

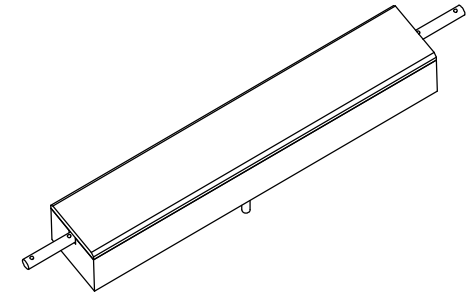

**Step 4:**  
Fix the Front Axle Support Cover in position, and use nails to secure in place.

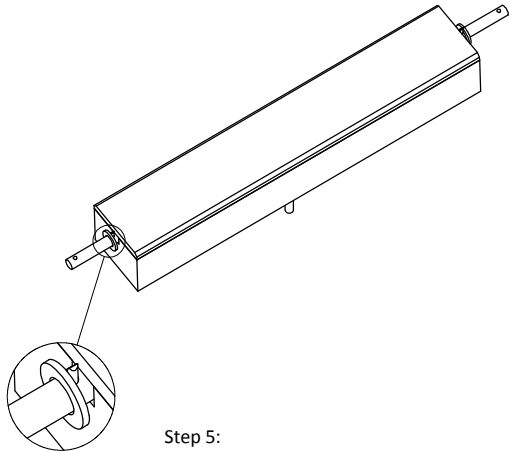

**DETAIL E**  
SCALE 1 : 3

**Step 5:**  
Insert a Split Pin (or a nail and bend the end of it so it will not come out) and a washer on either side of the Axle.

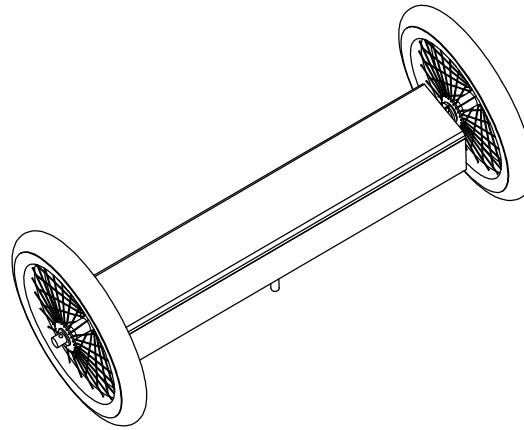

**Step 6:**  
Place the two wheels onto the ends of the Axle. Make sure to apply plenty of grease and oil so the wheels rotate smoothly. Depending on the size of the hole in the middle of the spoked wheel, there are two options:

1. Obtain a 15MM Drill bit and increase the size of the hole in the Wheel
2. Use a smaller diameter Axle (only advisable for the Front Axle)
3. File / Grind down the ends of the axle so the wheel can fit.

**DETAIL F**  
SCALE 1 : 3

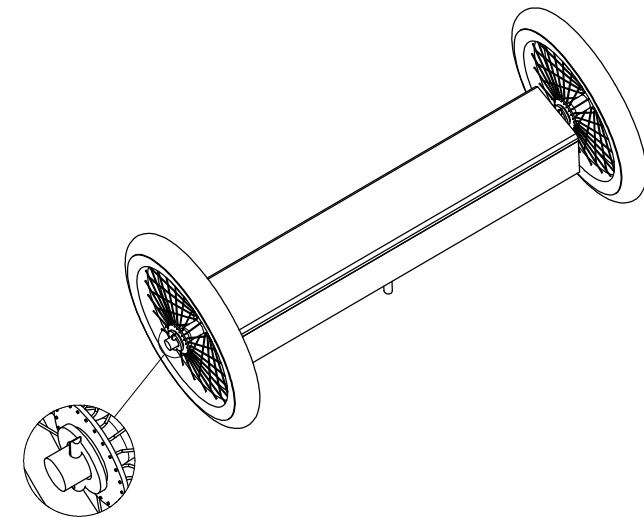

**Step 7:**  
Insert the final washer and split pins (or nails) into position on either end of the Axle. The Front Axle Assembly is now complete.

<small>PROPRIETARY AND CONFIDENTIAL THE INFORMATION CONTAINED IN THIS DRAWING IS THE SOLE PROPERTY OF THE DESIGNER. ANY REPRODUCTION IN PART OR AS A WHOLE WITHOUT THE WRITTEN PERMISSION OF THE DESIGNER IS PROHIBITED.</small>					
<b>TITLE: FRONT AXLE ASSEMBLY #2</b>					
MATERIAL AS SPECIFIED				DATE: 17/10/2009	
FILE NAME: Main-Wooden-Kart-			SIZE: A4	REV. 1	
SCALE: 1:20		DESIGNER: STEPHEN BURKE		SHEET 11 OF 21	