

DETAIL C
SCALE 1 : 2

The Steering Column is secured to the Bonnet Center using split-pins and washers. This allows the steering column to rotate freely without moving in/out.

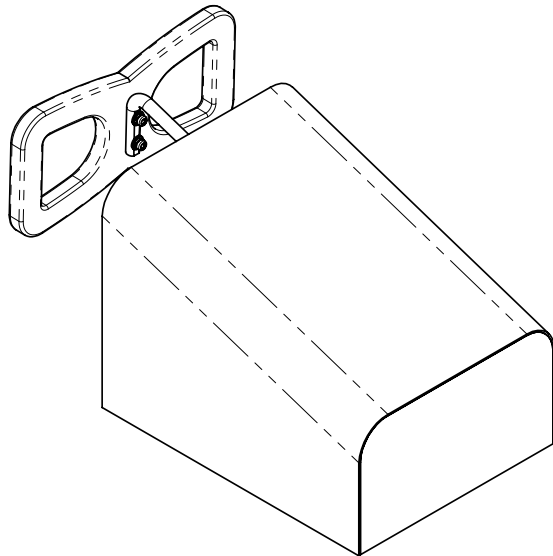
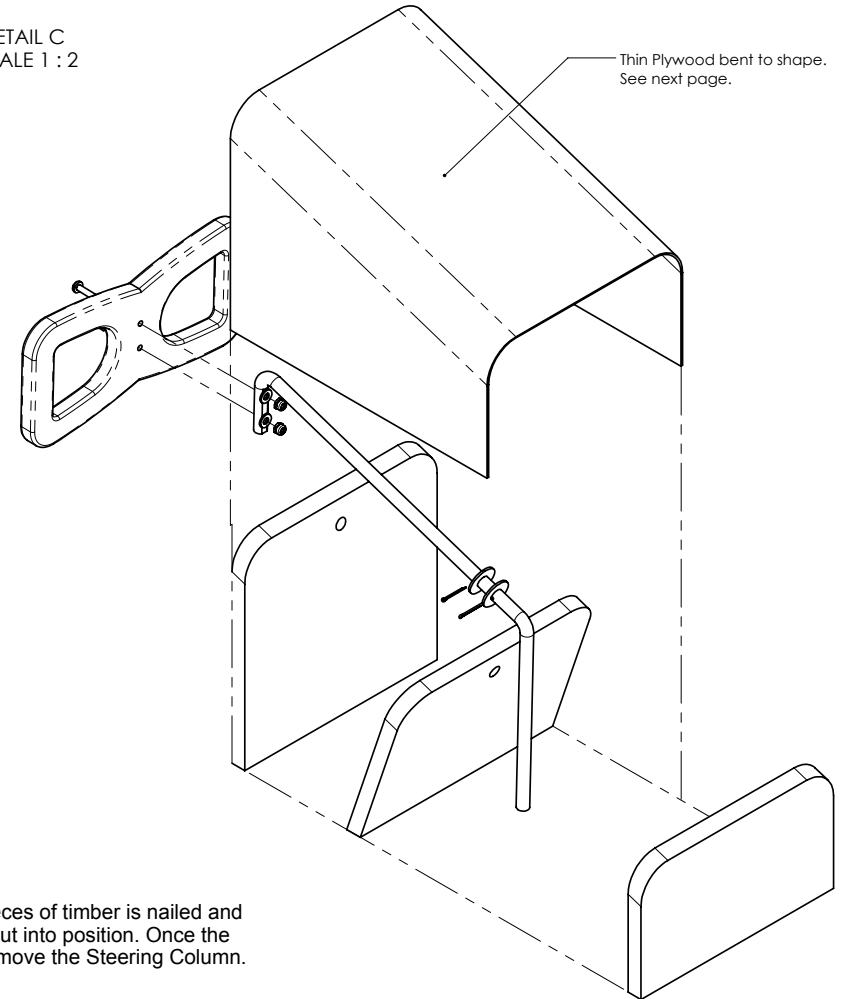

The assembly of the Bonnet is a little tricky. Before the pieces of timber is nailed and glued together, the Steering Column (Steel bar) must be put into position. Once the bonnet assembly is put together, it won't be possible to remove the Steering Column.

See next page for measurements and sizes of each part.

PROPRIETARY AND CONFIDENTIAL
THE INFORMATION CONTAINED IN THIS
DRAWING IS THE SOLE PROPERTY OF THE
DESIGNER. ANY REPRODUCTION IN PART OR
AS A WHOLE WITHOUT THE WRITTEN
PERMISSION OF THE DESIGNER IS PROHIBITED.

kartbuilding.net



TITLE: **BONNET ASSEMBLY 1**

MATERIAL AS SPECIFIED

DATE: 26/10/2010

FILE NAME: WOODEN-PUSH-CART

SIZE: A4 REV. 1

SCALE: 1:5

DESIGNER: STEPHEN BURKE

SHEET 8 OF 10

