

THE UNDERNEATH CAN BE FILED TO GIVE A CURVED MATING SURFACE WITH THE CHASSIS. (SEE SHEET 6)

THE SIZE OF THE ABOVE BRACKET DEPENDS SOLELY ON THE SIZE OF THE BEARING. THE REAR AXLE CARRIER ALLOWS A STANDARD ROLLER BEARING TO BE USED. IN COMBINATION WITH THE TRIANGULAR FACE PLATE, THE BEARING CAN BE SECURELY HELD IN POSITION WHILE THE REAR AXLE ROTATES. NOTE: THERE ARE OTHER SIMPLER SOLUTIONS AND BEARINGS WHICH CAN BE USED INSTEAD.

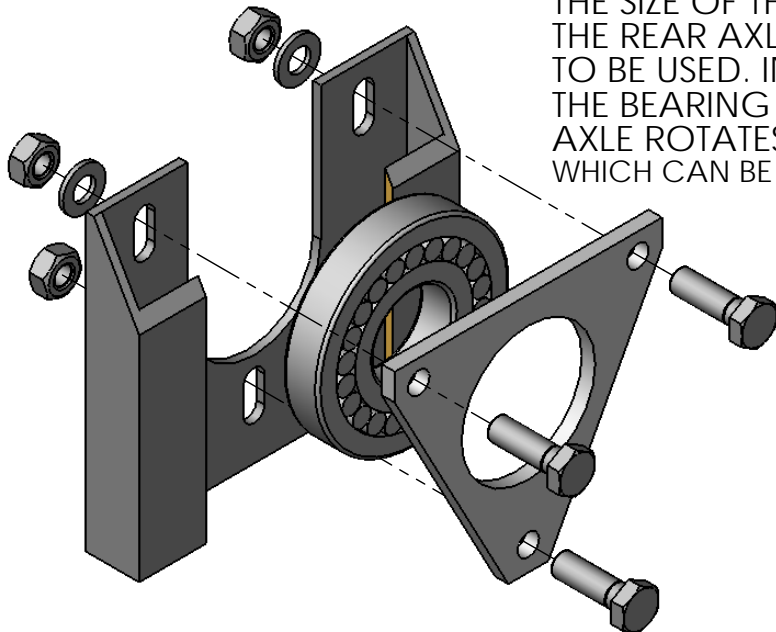

- MATERIAL:
- 3MM FLAT STEEL
 - BENT TO SHAPE

KARTBUILDING
FREE RACING KART PLANS

REAR AXLE CARRIER		www.kartbuilding.net
DRG. NO.: 5	DATE: 24/07/03	© STEPHEN BURKE