

KARTBUILDING  
FREE KART PLANS  
www.kartbuilding.net

3 REINFORCING SHOULDERS  
EQUI. SPACED. CAN BE WELDED  
IN PLACE IF REQUIRED.

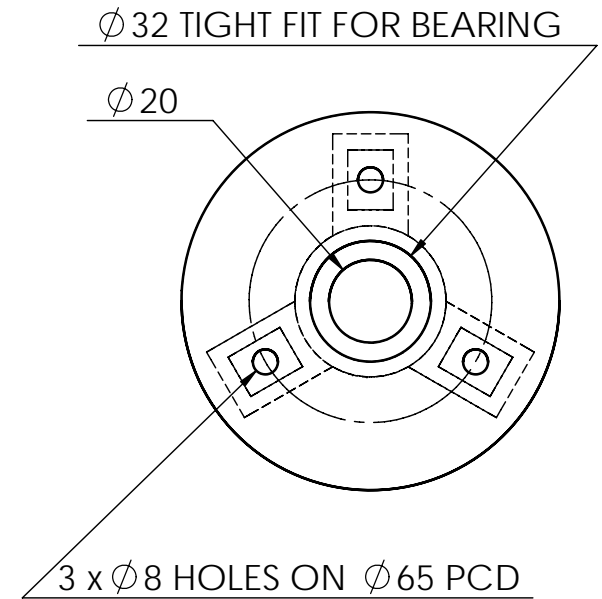
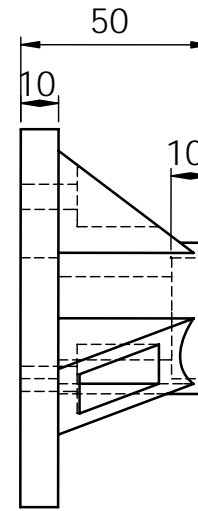
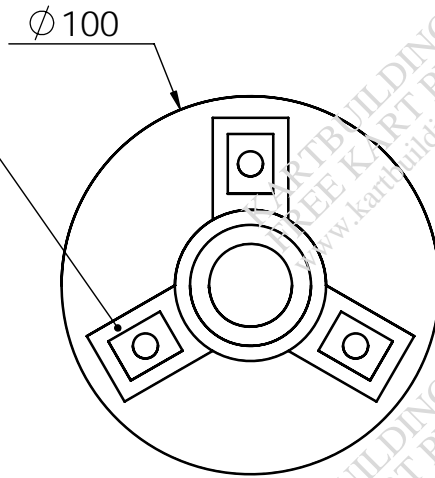

NOTE:  
IT MAY BE POSSIBLE TO  
BUY THESE ALUMINIUM HUBS  
FROM A KARTING CATALOGUE!  
THE HUB MUST SUIT THE TYPE  
OF WHEEL BEEN USED!

- MATERIAL:
- ALUMINIUM
  - TURNED/MANUFACTURED
  - POSSIBLY WELD ON REINFORCING SHOULDERS.

**KARTBUILDING**  
FREE RACING KART PLANS

FRONT HUBS AND WHEELS

www.kartbuilding.net

DRG. NO.: 10 DATE: 24/07/03

© STEPHEN BURKE

EXPLODED ASSEMBLY OF FRONT LEFT WHEEL AND HUB

KARTBUILDING  
FREE KART PLANS  
www.kartbuilding.net

KARTBUILDING  
FREE KART PLANS  
www.kartbuilding.net

KARTBUILDING  
FREE KART PLANS  
www.kartbuilding.net