

THERE ARE 3 DIFFERENT HOLES WHICH CAN RECIEVE THE CLUTCH CABLE. THE HOLE TOWARDS THE BOTTOM WILL ALLOW FOR BETTER CONTROL ON A SENSITIVE CLUTCH. THE HOLE AT THE TOP OF THE PEDAL IS FOR CLUTCHES WITH LONG TRAVEL WHICH ARE LESS SENSITIVE.

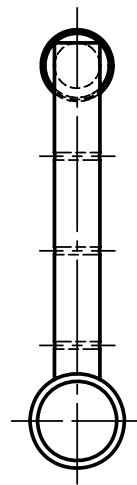

TUBING/PIPE WHICH CAN ROTATE FREELY

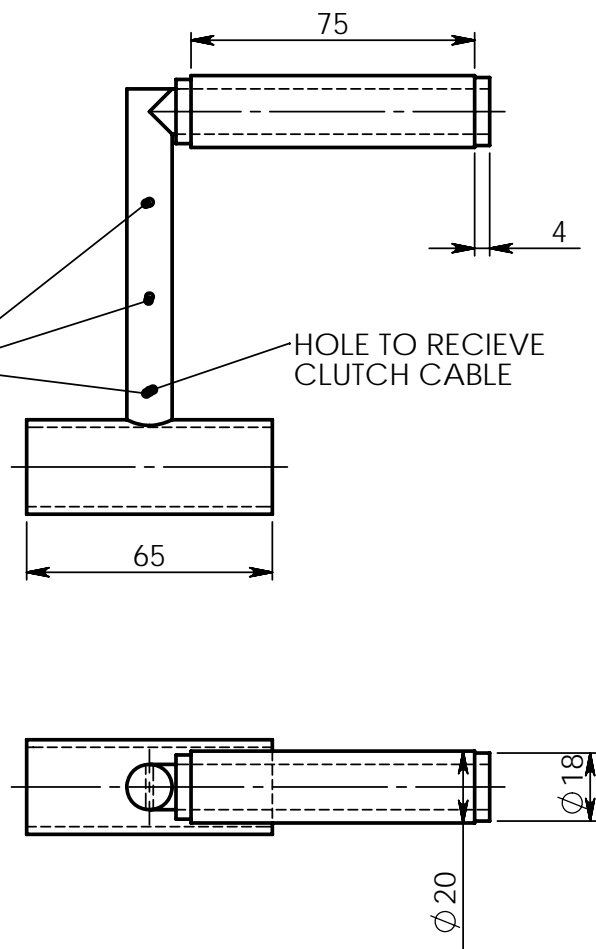
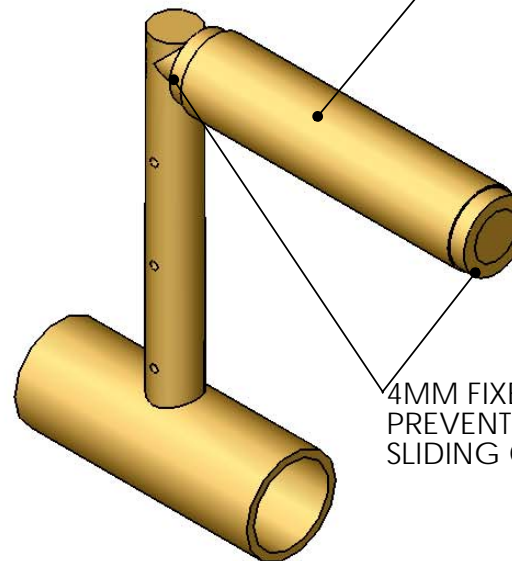

4MM FIXED/WELDED ENDS TO PREVENT ROLLER FROM SLIDING OFF THE PEDAL

KARTBUILDING
FREE KART PLANS
www.kartbuilding.net

AS THE CLUTCH PEDAL CAN BE OPERATING A MOTORCYCLE CLUTCH, IT NEEDS TO BE VERY SENSITIVE TO MOVEMENTS OF THE DRIVERS FOOT, ESPECIALLY WHEN DISENGAGING THE CLUTCH AND TAKING OFF. AS A RESULT - A ROLLER (PIECE OF TUBING/PIPE WHICH CAN SPIN FREELY) WILL HELP THE DRIVER TO LET OUT THE CLUTCH MORE CAREFULLY TO PREVENT STALLING THE KART WHEN TAKING OFF.

KARTBUILDING

FREE RACING KART PLANS

MODIFIED CLUTCH PEDAL

www.kartbuilding.net

DRG. NO.: ##

DATE: 24/07/03

© STEPHEN BURKE